

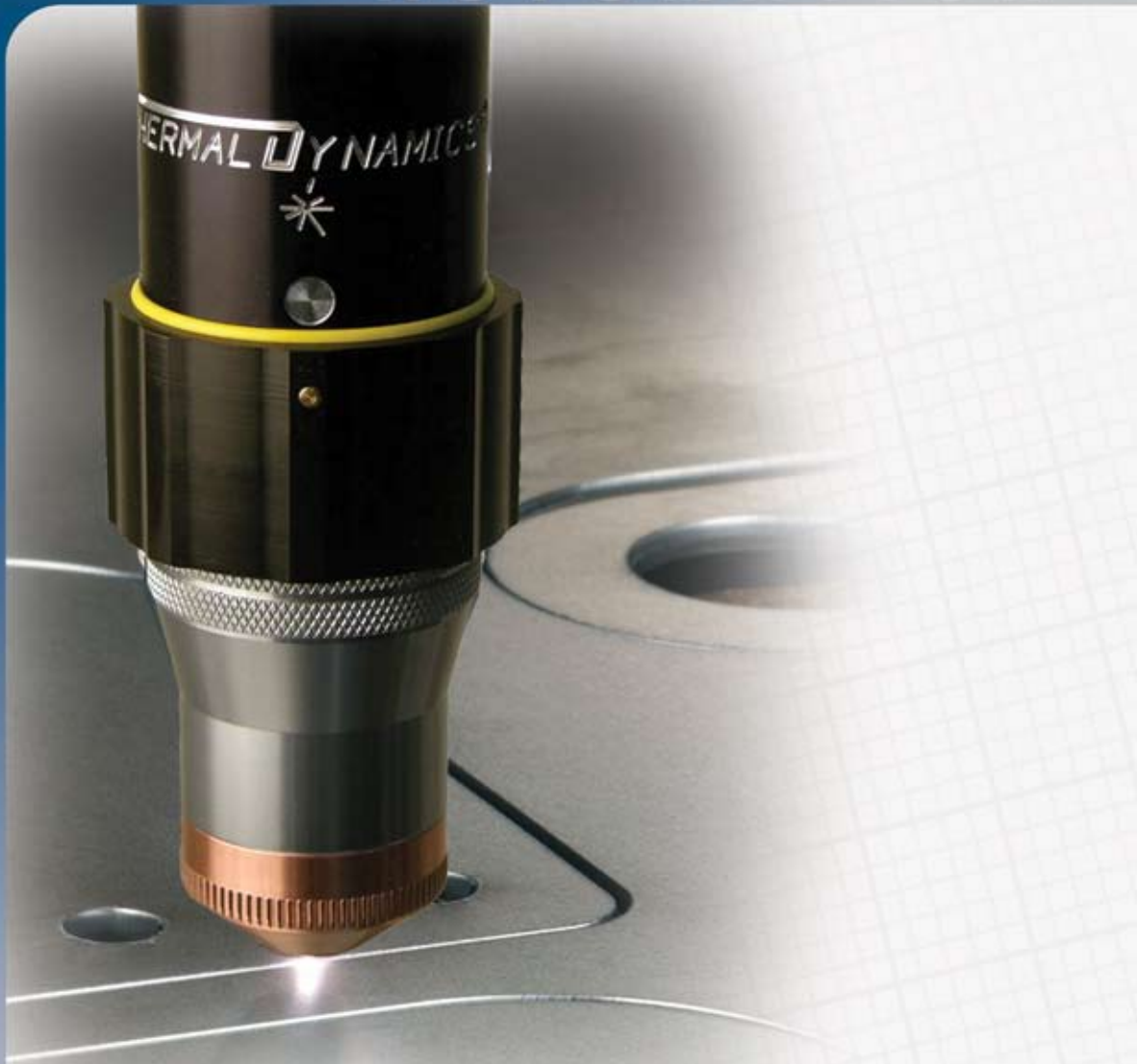

THERMAL DYNAMICS

AUTOMATION



Operator's Ready Reference

What is plasma?

Plasma is a gas heated to an extremely high temperature and ionized so that it becomes electrically conductive. Plasma arc cutting uses the plasma as an electrode to transfer a electrical arc to the work piece. The heat of the arc melts the work piece and the force of the plasma and shield gases blow away the molten metal to cut the work piece.

Different metals react differently to plasma cutting. Carbon steel can be oxidized, and is usually cut with a plasma containing oxygen to take advantage of the exothermic process. Higher levels of oxygen in the plasma result in higher heat and higher rates of oxidation. The result is a faster and cleaner cut. Stainless steel and aluminum are not subject to rapid oxidation and depend entirely on the plasma's heat for the cutting process. Because plasma produces much higher heat than the oxygen-fuel cutting process, plasma can cut stainless steel and aluminum quickly and cleanly.

Choosing a plasma process

Thermal Dynamics systems offer a variety of plasma cutting processes for precision and general purpose cutting. Ultra-Cut systems offer precision cutting as well as conventional cut options.

Auto-Cut O2 systems offer high speed oxygen cutting, precision non-ferrous and conventional cut options. Auto-Cut systems offer conventional mild steel and precision non-ferrous options.

Process		Used For	Advantages
Plasma	Shield		
O ₂	Air	Mild Steel Precision 50-300 Amps and High Speed Oxygen Process	Weld Ready Cut Surface
O ₂	O ₂	Mild Steel Precision at 30 Amps	Weld Ready Cut Surface
N ₂	H ₂ O	Precision Non-Ferrous	Best Cut Quality on Stainless and Aluminum to 3/4"
N ₂	N ₂	Conventional Thin Non-Ferrous	Better Parts Life Than Air Better Cut Surface Than Air on Non-Ferrous
H35	N ₂	Thicker Non-Ferrous >3/4" Aluminum >3/4" Stainless	Faster Cutting on Thicker SS and Aluminum Weld Ready Cut Surface H35=65%Ar/ 35%H ₂
Air	Air	Conventional Mild Steel	Economical Cost of Operation Good Cut Quality
Air	Air	Conventional Non-Ferrous	Economical Cost of Operation

Cut charts

Thermal Dynamics provides a cut parameters chart for every process and output current combination.

Material

Mild Steel

Current Level

30A

Process

O₂ Plasma / O₂ Shield

Consumable Parts

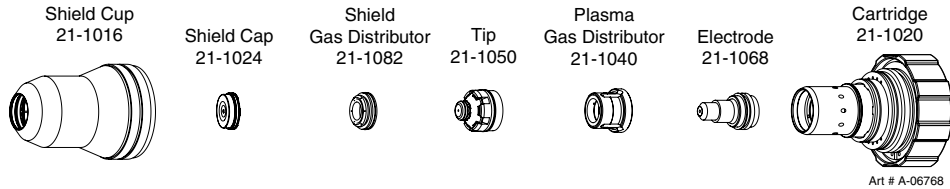

Kerf Size

30A Mild Steel (O ₂ /O ₂)													
Material Thickness			Pre Flow Pressure (Air)	Cut Flow Rates / Pressures				Arc Voltage	Torch Working Height	Travel Speed	Initial Piercing Height	Pierce Delay	Kerf Width @ Rec. Speed
				Plasma (O ₂)		Shield (O ₂)							
(ga)	(in)	inch	(PSI)	Ball	(PSI)	Ball	(PSI)	Volts	(in) ±0.005	(ipm)	(in)	(sec)	(in)
20		0.036	60	22	120	21	120	128	0.050	130	0.120	0.2	0.058
16		0.060	60	22	120	21	120	143	0.050	60	0.120	0.3	0.070
14		0.075	60	22	120	21	120	145	0.070	45	0.120	0.3	0.072
12		0.105	60	22	120	21	120	148	0.110	40	0.150	0.3	0.074
10		0.135	80	22	120	21	120	154	0.130	30	0.150	0.3	0.085
3/16		0.188	80	22	120	21	120	154	0.120	25	0.150	0.4	0.075

Pierce Data

Gas Control Settings

Arc Voltage for Torch Height Control

Material Thickness	Pre Flow Pressure (Air)	Cut Flow Rates / Pressures				Arc Voltage	Torch Working Height	Travel Speed	Initial Piercing Height	Pierce Delay	Kerf Width @ Rec. Speed
		Plasma (O ₂)		Shield (O ₂)							
(mm)	(Bar)	Ball	(Bar)	Ball	(Bar)	Volts	(mm) ±0.1	(mm/min)	(mm)	(sec)	(mm)
1	4.1	22	8.3	21	8.3	130	1.3	3050	3.0	0.2	1.5
2	4.1	22	8.3	21	8.3	145	1.9	1130	3.1	0.3	1.8
3	4.1	22	8.3	21	8.3	150	3.0	910	3.8	0.3	2.0
4	5.5	22	8.3	21	8.3	154	3.2	710	3.8	0.3	2.1
5	5.5	22	8.3	21	8.3	155	3.0	640	3.8	0.4	1.9

Marking (with 30A Mild Steel Parts)											
15A Arc Current	Pre Flow Pressure (N ₂)	Cut Flow Rates / Pressures				Arc Voltage	Torch Working Height	Travel Speed	Initial Piercing Height	Pierce Delay	Marking Quality Degrades as Thickness Decreases.
		Plasma Pressure (N ₂)		Shield Pressure (N ₂)							
		Ball	Press	Ball	Press						
Burn-through may occur on thicknesses < 1/16" (0.063") / 1.6 mm	20psi / 1.4 bar	20	40 psi / 2.8 bar	70	80 psi / 5.5 bar	145	0.1 / 2.5	300 / 7600	0.1 / 2.5	0	

Plasma Marking Parameters

Consumable parts

Parts selection

Consumable parts are specifically designed to perform in specific conditions. Using the wrong consumable parts will result in short parts life and poor cut quality. Use the cut charts to determine which consumable parts to use in any specific application.

Installing consumable parts

The XT torch is a precision instrument. Take care when installing consumable parts to keep the parts clean and free from any contamination that might cause a gas or coolant leak inside the consumable parts cartridge.

Assembly Sequence, 30-150 Amp Consumables

7.04 Torch Consumables Installation



WARNINGS

Do not install consumables into the Cartridge while the Cartridge is attached to the Torch Head. Keep foreign materials out of the consumables and Cartridge. Handle all parts carefully to avoid damage, which may affect torch performance.

Art # A-03887

1. Install the consumables as follows:

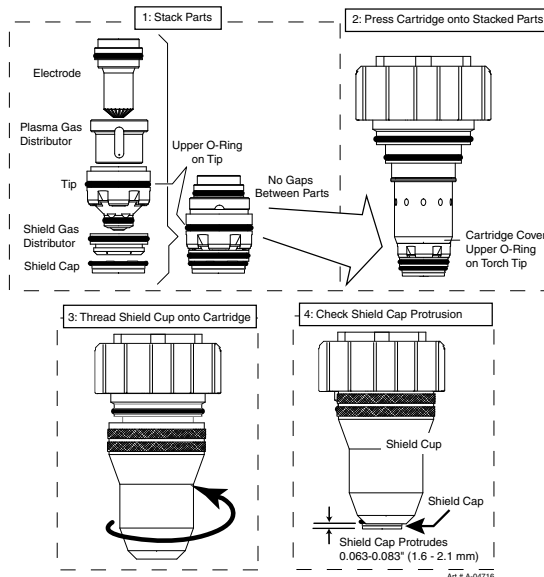

Assembly Sequence, 200/300 Amp Consumables

Art # A-07424

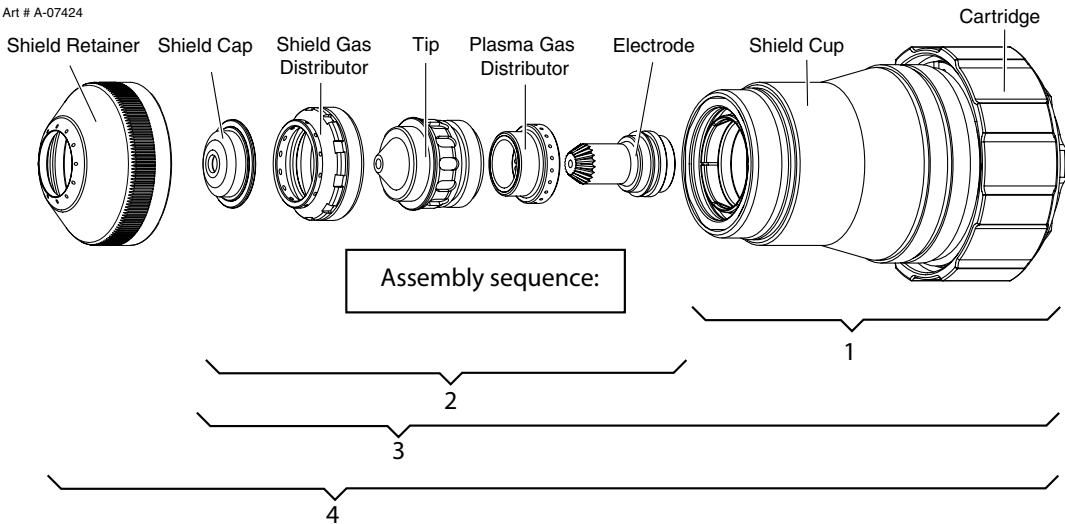

To ensure proper assembly of the torch cartridge:

- 1. Place the cartridge assembly on a clean, flat surface*
- 2. Assemble the consumable parts from electrode to shield cap.*
- 3. Install the consumable parts in the cartridge*
- 4. Install the shield retainer to complete the cartridge assembly.*

Consumable Parts Life

Tips and electrodes wear under normal usage. Tips and electrodes should be changed before failure to avoid damaging the other consumable parts or the material to be cut. Optimum life will vary according to specific cutting conditions. Keep a count of cuts per set of tip and electrode in a given application to establish the most effective time to change consumable parts sets. The pilot arc is more erosive to the tip and electrode than the cutting arc is, so an application that demands more pilot and pierce sequences will erode consumable parts faster than an application that uses longer cuts but fewer arc starts.

Tip – Tips wear as the arc erodes the tip orifice. When the tip is no longer round or has become enlarged, it should be replaced. Tip life is best when cuts are made at optimum speed. Cutting too fast or too slow causes the arc to bend and biases erosion, resulting in an orifice that is oval shaped.

Electrodes – The electrode wears from the hafnium or tungsten insert at the end of the electrode. The face of the insert is liquefied by the heat of the arc and droplets erode from the insert as cutting progresses. Proper gas flow will support longer electrode life. An electrode should be replaced when the electrode insert is pitted to a depth of 1/16 inch (see chart below).

Replace the Gas Distributor if it is charred or cracked

Replace the Gas Distributor if the flange is damaged in any way

Replace the tip and/or electrode if they are worn

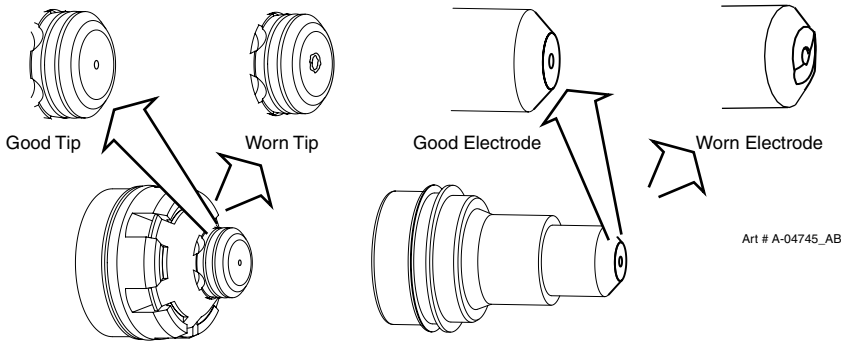

Art # A-04745_AB

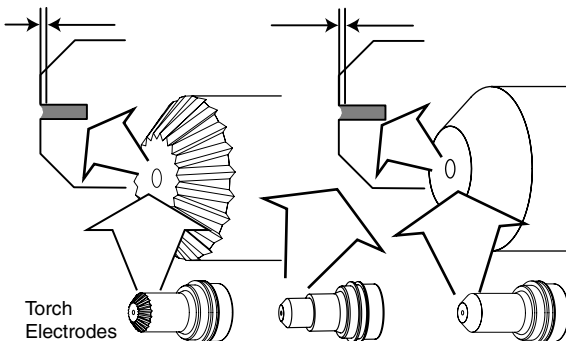

Torch
Electrodes

Amperage	Plasma Gas	Recommended Wear Depth for Replacement	
		Inch	mm
30	O2	0.04	1
	Air	0.04	2
50	O2	0.04	1
	Air	0.08	2
70	O2	0.04	1
	Air	0.08	2
100	O2	0.04	1
	H35	0.08	2

Art # A-04704_AB

Cut characteristics

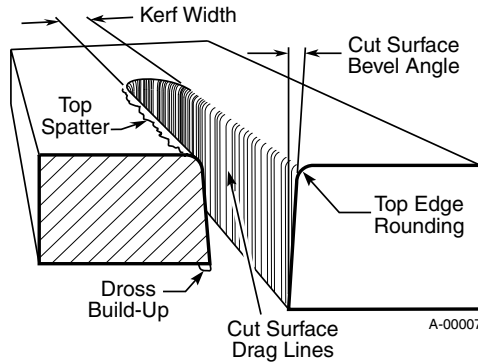

Cut Surface – Cut surface is influenced by process and positioner precision more than by other parameters. For smoothest cut face on different materials, use: mild steel – oxygen plasma

stainless < 3/4" – nitrogen / WMS
> 3/4" – H35 / nitrogen

aluminum < 3/4" – nitrogen / WMS
> 3/4" – H35 / nitrogen

Direction of cut – The plasma has a clockwise swirl as it exits the torch tip. Considering the direction of torch travel, the right side of the cut will always show less bevel and top edge rounding than the left side. Program cuts so that the right side will be on the finished part and the left side will be scrap.

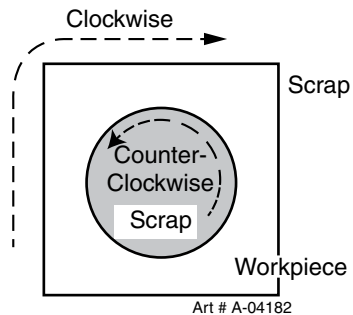
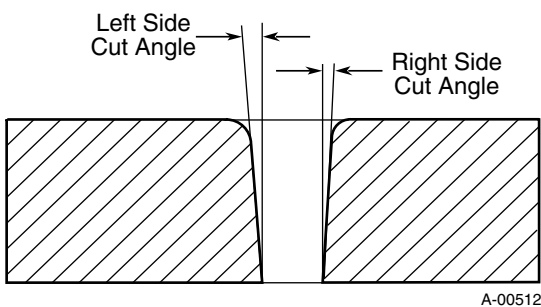

Top edge rounding – Caused by the heat of the plasma arc at the top surface of the cut. Proper torch height control can minimize or eliminate top edge rounding. Excessive top edge rounding is often a sign that torch cutting height should be lower.

Top spatter – Top spatter is caused by fast cutting or by too high a torch height setting. Reducing cut speed or lowering torch cutting height will reduce top spatter. Top spatter is easy to remove.

Bottom dross – Molten metal may build up on the bottom of the plate. Faster cut speeds reduce bottom dross as less material is melted. Bottom dross that is easy to remove is an indication of slow cutting speed. Bottom dross that is difficult to remove or requires grinding is an indication of too fast cut speed.

Kerf – Kerf width is specified in the cut charts and can be calculated into cut programs. The kerf width is related to tip orifice size and higher current cutting will produce a wider kerf. Higher torch height will also result in a wider kerf.

Bevel angle – Precision cut processes produce bevel angle in the 0-3° range. Conventional plasma cutting will produce larger bevel angles. Proper torch height control will produce the smallest bevel angle, as well as improved kerf width and minimal top edge rounding. A slower cut speed can be used when cutting circles and corners to reduce bevel.

Effect of Height Control Settings – General Purpose Cut

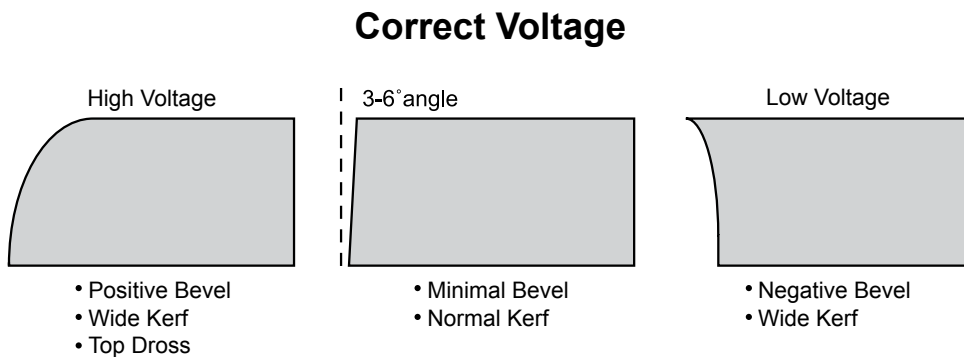

Nitride contamination – Air plasma cutting will produce nitride contamination of the cut face on carbon steel and stainless steel. Nitride contaminated surfaces will require grinding before welding to eliminate weld porosity. The depth of the contamination will be close to the Heat Affected Zone, between .005 and .010" in depth.

Nitride contamination can be eliminated by using a process other than air plasma; oxygen plasma for carbon steel, H35 or nitrogen/WMS for non-ferrous materials.

Cut speed – Cut charts specify a cut speed that will produce high quality cut performance. Any plasma system can cut at faster or slower speeds, but cut performance will be affected. Cut speed should be reduced for corners and tight curves to reduce bevel and corner rounding.

Optimum cut speeds produce a trailing arc which will be visible in the slight arc lines visible in the cut face. Arc lines are useful for evaluating cut speed on mild steel, but less so for aluminum and stainless steel. Arc lines that trail at less than 15° indicate that cut speed is in the optimum range when air or oxygen plasma processes are used. Optimum cut quality in precision cutting processes will result in arc lines that are near vertical. A slow cut speed may show arc lines that angle forward and a fast cut speed will show arc lines at a sharper angle relative to the top of the plate.

Aluminum

Cut Speed Too Fast



*Cut drag lines are more than 15 degrees trailing the torch (torch movement right to left)
High speed bottom dross, easy to remove*

Cut Speed Correct



Cut drag lines trail are visible, but cut surface is smooth. No dross

Cut Speed Too Slow



Cut drag lines are more pronounced and cut surface is rougher

Stainless Steel (H35 plasma)

Cut Speed Too Fast

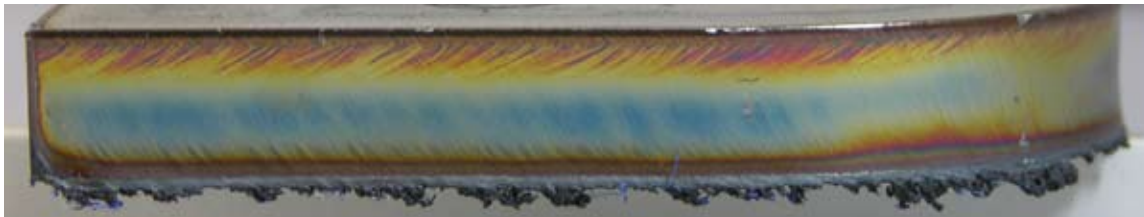

*Gold heat discoloration swept in both directions
Cut drag lines more than 15 degrees trailing
High speed bottom dross, hard to remove*

Cut Speed Correct



*Smooth cut surface
No dross*

Cut Speed Too Slow

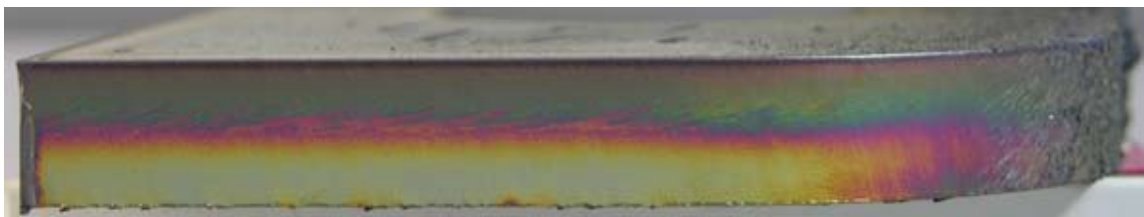

*Heat discoloration is concentrated in the bottom half of the cut
Hard bottom dross, hard to remove*

Mild Steel (O₂ plasma)

Cut Speed Too Fast



*Trailing cut drag lines
Light bottom dross, hard to remove, some top splatter*

Cut Speed Correct



*Cut drag lines near vertical
No dross*

Cut Speed Too Slow



*Cut drag lines lead the torch
Heavy bottom dross, easy to remove*

Mild Steel (Air plasma)

Cut Speed Too Fast



*Cut drag lines curve and trail torch movement
High speed bottom dross, hard to remove*

Cut Speed Correct



*Cut drag lines near vertical
Minimal dross*

Cut Speed Too Slow



*Cut drag lines vertical or leading the torch head
Thicker bottom dross, easy to remove*

Cutting Circles

Circle cutting demands precise motion control and circle cut quality will vary as the circle diameter approaches the thickness of the plate. In general, a circle that is equal in diameter to the thickness of the plate being cut is the minimum circle diameter possible. Cut quality will decrease markedly when the circle diameter is less than 1.5 times the thickness of the plate being cut.

For maximum circle cut quality:

1. Slow down cut speed. Smaller circles may require a cut speed that is 60-50% of the speed specified in system cut charts. A slower cut speed will eliminate trailing arc and allow the arc to cut at closer to 0° of bevel.
2. Maintain constant cut height through the circle. This may require locking out the height controller. As the cut speed slows, arc voltage increases and the height controller tends to drive the torch down, changing cut bevel. Avoid torch height movement by locking out the height controller during the circle cut.
3. Start the cut in the center of the circle and use a 90° lead-in to the circle. When the positioner is in top running condition, a 90° lead-in will produce less distortion at the circle initiation. A cutting table with backlash may produce a better cut when a radial lead-in is used.
4. End the cut by overburning the circle cut line rather than by using a lead-out. Time the cut to end just as the arc completes the circle. A lead out or too much of an overburn will cause the arc to cut more of the outside of the circle and cause a distortion at the point where the circle cut is completed. Many CNC systems use an advanced off feature to ramp down cutting current end of cut. Use of the CNC's advanced off feature will improve circle cutting.

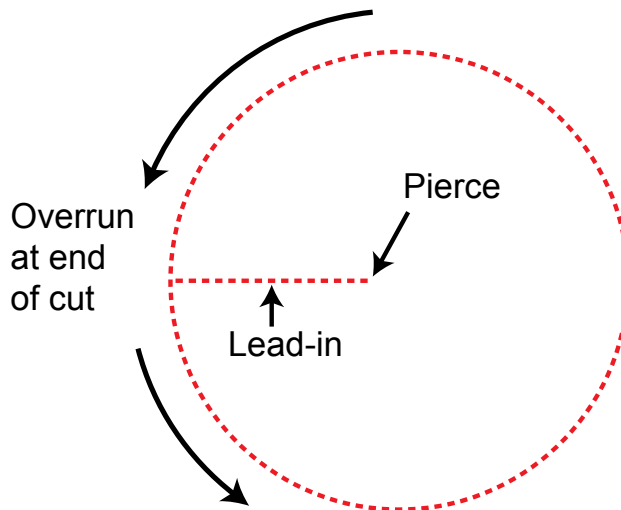

N2/Water Mist Secondary[®]

In this process, tap water is used instead of a shield gas. The water is vaporized as it passes through the torch head and a portion of the molecules separate onto hydrogen and oxygen. This vapor protects the cut surface from ambient air contamination and eliminates nitriding in the cut surface.

Cutting with the N2/WMS process is economically efficient and produces genuine precision cut quality over a broad range of non-ferrous applications.

Considerations:

- *Water supply should be at least 55 psi.*
- *Hard water will leave mineral deposits, just as it does in sinks and faucets. A standard water softening filter will prevent mineral deposits that can interfere with water flow in the torch passages.*
- *Ohmic sensing to establish initial torch height is ineffective when water is present. The ohmic clip should be removed from the torch for N2/WMS cutting. The ohmic sensing system will sense the level of any water on the plate rather than the true position of the plate.*

Underwater Cutting

Cutting under water is used by some operators to capture smoke and reduce flash and noise. Cutting under water is possible with Ultra-Cut and Auto-Cut systems.

Considerations:

- *Cutting under water will reduce cut capacity and speed by up to 30%*
- *The cooling effect of water on the bottom of the plate will facilitate formation of dross*
- *Cutting aluminum under or over water releases hydrogen, which can explode*
- *Cutting with N2/WMS process is not recommended*
- *The water in the table will become contaminated with cut residue and can be a toxic waste*

Power Supply Status Codes

Auto-Cut and Ultra-Cut systems display system status codes that are useful for optimizing system performance and for troubleshooting. The status code is displayed on the power supply front panel.

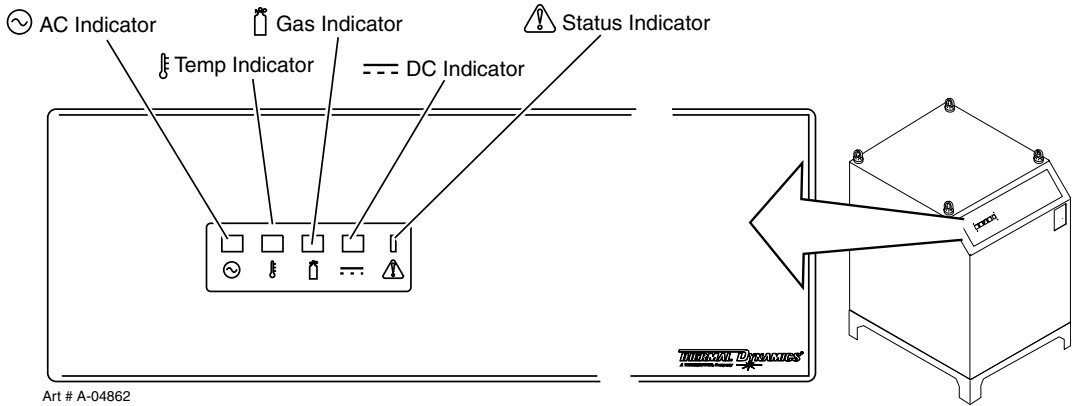

AC Power Indicator: Indicates AC power is being supplied to the system when the ON/OFF switch is in ON position. When switch is first set to ON, the indicator will blink, indicating gas purge at power on.

TEMP Indicator: Normally OFF. Indicator will come ON when the internal temperature sensors detect temperatures above normal limits. Let the unit cool before continuing operation.

GAS Indicator: Normally ON. Indicates adequate gas pressure for operation in the system.

DC Indicator: Indicates the power supply is generating output DC voltage.



Status Indicator: Show system status. The number of flashes indicates the status.

Refer to the Status Code Section for details. On power supply start-up, the indicator flashes to show the revision level of the operating software installed in the system.

The Status Indicator flashes a 2 part code that indicates the status of the system. When the Status Indicator is dark the system is ready to cut. It is normal for the Status Indicator to flash when the GCM mode switch is placed in set mode. At system start up, the Status Indicator flashes a 2 part code to indicate the CCM firmware version that is loaded into the system. This code appears only once at start up. During normal operation the Status Indicator may flash a code indicating an error or a condition that should be corrected. Some codes will cause the system to cease operation to prevent damage to the hardware. Other codes will not cause the system to cease operation, but will continue until the condition which caused the code to initiate is changed.

Status codes appear in a 2 part sequence. The Status Indicator will flash a number of times to indicate the first number in the code sequence, then pause for 1.2 seconds and flash the second number of the code. After 4 seconds, the code sequence will repeat.

Example: The Status Indicator blinks 4 times, pauses, then blinks 3 times. This code (4-3) indicates overheating coolant and will continue until the condition is corrected.

Status Indicator Codes

Fault Code Key		
Error Code	Error	Remedy / Comments
1-1	System not Enabled or Missing AC Input Phase	Plasma Enable Off ; External E-Stop Activated or CCM TB1-1&2 jumper missing; Missing AC Phase; No power to GCM 2000 or 2010 Gas Control, check GCM control cable connected, reset CP4 or CP5 circuit breaker in power supply, blown fuse F19 in GCM.
1-2	Pilot Ignition Failure	Pilot did not start within 15 seconds. Preflow pressure too high; Defective Arc Starter
1-3	Lost Pilot	Pilot went out without shutoff signal; Preflow pressure too high; cut current set too low for consumables.
1-4	Loss of Transfer	Arc transfer (>50 ms.) then arc lost with START still on. Standoff too high; Current set too low.
1-5	Off the Plate	Function not currently enabled
1-6	Pilot Timed out w/o Transfer	Must transfer from Pilot to Cutting Arc in 85 ms. (SW8-1 OFF) or 3 sec. (SW8-1 ON). Standoff too high or void in work under torch; cut current too low for consumables; Preflow pressure too low.
1-7	Tip Saver	Function not currently enabled.
1-8	Possible Shorted Torch	Detected tip voltage too close to electrode voltage. Plasma flow/pressure too low; Plasma leak; cut current too high; shorted torch body; consumable parts worn out.

Fault Code Key		
Error Code	Error	Remedy / Comments
2-1	Missing Phase	Blown fuse, Broken or loose connection on power cable
2-2	Wrong input voltage	Inverter(s) not configured correctly for input voltage; Poor power quality (brownouts, dropouts); Input power capacity / wiring too small causing voltage drop; broken or loose power cable connections.
2-3	Inverter or Pilot Regulator Over Temperature	Failed fan; Ambient above 40 deg C. (104 F); Blocked airflow
2-4	Power Supply not Ready	Defective inverter
2-5	DC Output Low	Output less than 60 VDC; Defective inverter, shorted output; Shorted pilot regulator (chopper); CCM voltage sense (J6) wire open or disconnected.
2-6	Primary over current fault	Over current detected in inverter primary circuit, remove power to reset; defective inverter; voltage surge;
2-7	Unexpected current	Current >20A in work or pilot leads before pilot ignition; Possible shorted torch; Defective current sensor.
2-8	Unexpected current in pilot circuit	Current > 5A in pilot circuit; wrong or mismatched consumables; Pilot lead shorted to negative in torch tube; Possible shorted torch
2-9	Unexpected current in work lead	Current > 5A in work lead; Short to chassis in RAS; Negative lead short to ground.

Fault Code Key		
Error Code	Error	Remedy / Comments
3-1	Gas Control Communication fault, Cannot establish Communication with gas control.	If GCM 1000: Control cable not connected or Basic ID signal open. GCM 2010 & 2000: Dirt on fiber ends or in connectors, blow out with clean dry air; fiber not locked into connector; sharp bends in fiber; fiber defective; Gas Control PCB defective, replace. CCM defective, replace.
3-2	Gas Control Communication reply fault, connection was established but CCM did receive a reply to a process request.	Gas Control did not reply to signal from CCM in allowed time. Dirt on fiber ends or in connectors, blow out with clean dry air; fiber not locked into connector; sharp bends in fiber; fiber defective. If problem persists Gas Control PCB likely defective, replace board.
3-3	Gas Pressure Low	If GCM 1000, Plasma < 15 PSI; faulty or disconnected pressure SW. If GCM2010_AG, GCM2000_AC or later or Gas Control has been updated with 19X2219_AG or later PCB: Plasma or Shield input out of range 105-135. If GCM2010_AG, GCM2000_AC or later or Gas Control has been updated with 19X2219_AG or later PCB: Plasma or Shield input out of range 105-135 PSI; Unplugged or Faulty pressure sensor.
3-4	Gas Control not ready	Purging; not in RUN mode; Gas Control faulty, replace PCB.
3-5	Gas Control Protocol Fault	Application error or firmware compatibility fault
3-6	Invalid Current Control level from GCM	GCM sent output current level outside the range of the power supply, Check firmware compatibility
3-7	Gas Control returns wrong command sequence	Check firmware compatibility
3-8	CCM and Gas Control type (Autocut-Ultracut) mismatch	Install correct CCM or Gas Control for system
3-9	Gas Control Communication reply fault	Reply not compatible with request; Check firmware compatibility
3-10	Warning. -- Gas Control firmware needs update	System will function but control may not be optimized for best performance / consumable life

Fault Code Key		
Error Code	Error	Remedy / Comments
4-1	Coolant Level low fault	Check coolant level, add as needed.
4-2	Low coolant flow after power on purge. Not cutting: < 0.7 gal/min for 15 sec; Cutting: flow between 0.35 to 0.7 gal/min for 3 sec. or immediately if < 0.35gal/min;	Suction leak introducing air into coolant, suspect rear panel filter seal; clogged filter; defective pump.
4-3	Coolant overheated (>70 deg. C, 158 deg F)	Coolant fan failed; radiator fins clogged with dirt; Ambient temperature > 40 deg C.
4-4	Coolant System not ready. During power on purge / priming, flow did not reach 0.35 gal/min for at least 5 seconds	If new installation recycle power to restart pump, may take a few times to fill hoses; Damaged torch coolant tube; Suction leak introducing air into coolant, suspect rear panel filter seal; clogged filter; defective pump.
4-5	Low Coolant Level - Warning	While cutting detected low coolant level, does not stop cut. Add coolant as required.

Fault Code Key

Error Code	Error	Remedy / Comments
5-1	CANBUS Failure to Acknowledge fault.	If GCM 1000, Basic ID signal missing; Other gas controls, Fiber disconnected or broken, Transceiver (what fiber plugs into) fault, replace Gas control PCB or CCM
5-2	CANBUS Off due to excessive data errors;	Dirt on fiber ends or in connectors, blow out with clean dry air; fiber not locked into connector; sharp bends in fiber; fiber defective;
5-3	CANBUS data error warning. Errors increasing, will soon fault.	Dirt on fiber ends or in connectors, blow out with clean dry air; fiber not locked into connector; sharp bends in fiber; fiber defective;
5-4	CCM Message not sent	Dirt on fiber ends or in connectors, blow out with clean dry air; fiber not locked into connector; sharp bends in fiber; fiber defective; CANBUS hardware error (CCM or Gas Control PCB)
6-1	CCM Analog Voltage Error	Replace CCM
6-2	CCM ADC or DAC error	Replace CCM
6-3	Coolant Flow too High error, flow > 2.7 gal/min	Torch coolant tube broken or missing; CCM fault, replace CCM
6-4	CCM Data Memory error	Replace CCM

Scheduled Maintenance

Lubricate Torch Cartridge O-Rings

Lubricate all three O-Rings on the Cartridge Assembly and all three O-Rings on the Torch Head periodically with O-Ring Lubricant supplied. Remove the snap ring on the cartridge assembly and slide the locking ring downward for access to the O-Ring under the locking ring.

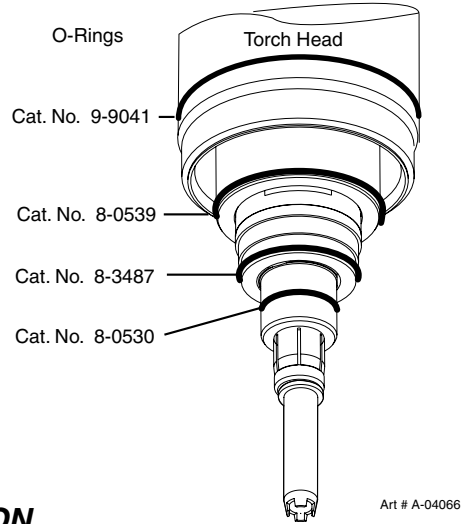
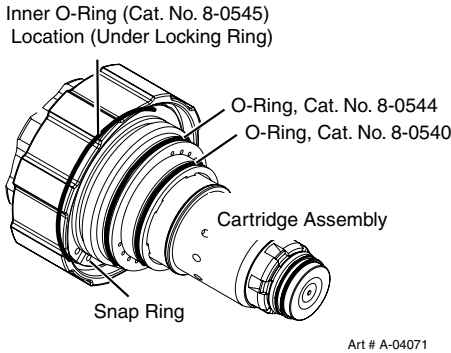

CAUTION

Use only Thermal Dynamics No. 9-4893 O-Ring Oxygen Compatible Lubricant (Christo Lube MCG-129) with this torch part. Use of other lubricants may cause irreparable damage to the torch.

An O-ring replacement kit with both torch and cartridge rings is available, catalog number 9-9488.

Coolant

Torch coolant becomes conductive with use and eventually will cause a shorted torch condition. Torch coolant should be replaced every six months. Also remove and clean the external coolant filter and the smaller filter located near the flow sensor.

Torch coolant is available pre-mixed or as concentrate.

Catalog Number	Description	Propylene Glycol/ Deionized Water Mix	Freeze Protection
7-3580	Extra-Cool™	25/75	10°F / -12°C
7-3581	Ultra-Cool™	50/50	-27°F / -33°C
7-3582	Extreme-Cool™	Concentrate to be mixed with De-I™ Water	-65°F / -51°C
7-3523	De-I Water™		32°F / 0°C

Periodic Maintenance

Power Supply Maintenance Schedule
Daily
<i>Check coolant level; add coolant as needed.</i>
<i>Check gas hose connections and pressures.</i>
<i>Check cooling fan; clean as needed.</i>
Monthly
<i>Check cooling fan and radiator; clean as needed.</i>
<i>Check gas hoses for cracks, leaks, or abrasions. Replace as needed.</i>
<i>Check all electrical connections for cracks or abrasion. Replace as needed.</i>
<i>Clean water filter (if using H₂O Mist).</i>
Six Months
<i>Replace coolant filter.</i>
<i>Clean coolant tank.</i>
<i>Vacuum out any dust buildup inside power supply.</i>

Troubleshooting Torch Coolant Leaks

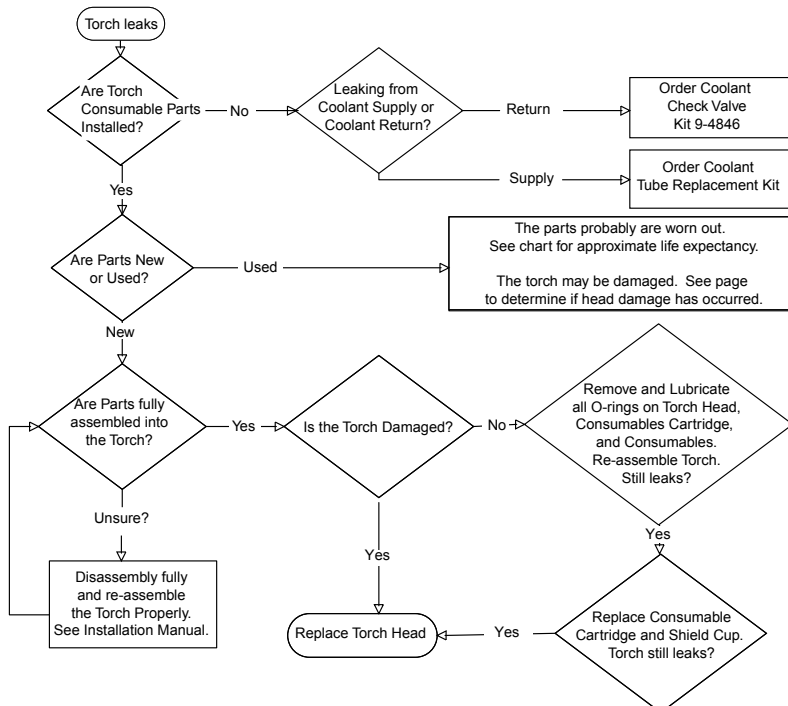

Technical Service Contact Numbers

Thermal Dynamics Technical Service is available for telephone or e-mail support. Technicians are available to assist with installation, application and repair issues.

Technical Service Toll Free – 1-800-PLASMA2 (752-7622)

Automation Technical Service – 1-888-832-3477

Automation Customer Care – 1-866-279-2628

General Customer Care – 1-800-PLASMA1 (752-7621)

E-mail - tdctech@thermadyne.com

www.thermal-dynamics.com

U.S. Customer Care: ARCAIR® / STOODY® / THERMAL ARC® / THERMAL DYNAMICS® / TWECO® / VICTOR® 800-426-1888 / FAX 800-535-0557
FIREPOWER® 800-858-4232 / FAX 800-535-0557 TDC AUTOMATION 866-279-2628 / FAX 800-221-4401
TURBOTORCH® 800-238-0282 / FAX 800-535-0557 VICTOR MEDICAL 800-382-8187 / FAX 800-535-0557
VICTOR SPECIALTY PRODUCTS 800-569-0547 / FAX 800-535-0557

Canada Customer Care: 905-827-4515 / FAX 800-588-1714 • International Customer Care: 905-827-9777 / FAX 905-827-9797
CIGWELD Customer Care: 1300-654-674 / FAX 613+ 9474-7391 • www.thermadyne.com



WORLD HEADQUARTERS: 16052 Swingley Ridge Road, Suite 300 • St. Louis, Missouri 63017 U.S.A.

A Global Cutting & Welding Market Leader™

THE AMERICAS

Denton, TX USA
U.S. Customer Care
Ph: (1) 800-426-1888
Fax: (1) 800-535-0557

Miami, FL USA
Sales Office, Latin America
Ph: (1) 954-727-8371
Fax: (1) 954-727-8376

Oakville, Ontario, Canada
Canada Customer Care
Ph: (1) 905-827-4515
Fax: (1) 800-588-1714

International Customer Care
Ph: (1) 905-827-9777
Fax: (1) 905-827-9797

EUROPE

Chorley, United Kingdom
Customer Care
Ph: (44) 1257-261755
Fax: (44) 1257-224800

Milan, Italy
Customer Care
Ph: (39) 0236546801
Fax: (39) 0236546840

ASIA/PACIFIC

Cikarang, Indonesia
Customer Care
Ph: 62 21+ 8983-0011 / 0012
Fax: 62 21+ 893-6067

Osaka, Japan
Sales Office
Ph: 816-4809-8411
Fax: 816-4809-8412

Melbourne, Australia
Australia Customer Care:
Ph: 1300-654-674
Fax: 613+ 9474-7391

International:
Ph: 613+ 9474-7508
Fax: 613+ 9474-7488

Rawang, Malaysia
Customer Care
Ph: 603+ 6092-2988
Fax: 603+ 6092-1085

Shanghai, China
Sales Office
Ph: 86 21+ 6280-1273
Fax: 86 21+ 3226-0955

Singapore
Sales Office
Ph: 65+ 6832-8066
Fax: 65+ 6763-5812