

300 Amp Diffuser

| Part No. | Stock No. | |
|-----------|-----------|--------------------|
| EL51 | 1510-1105 | Use with EL11 Tips |
| QTRW53-11 | 1525-1141 | Use with 11RS Tips |

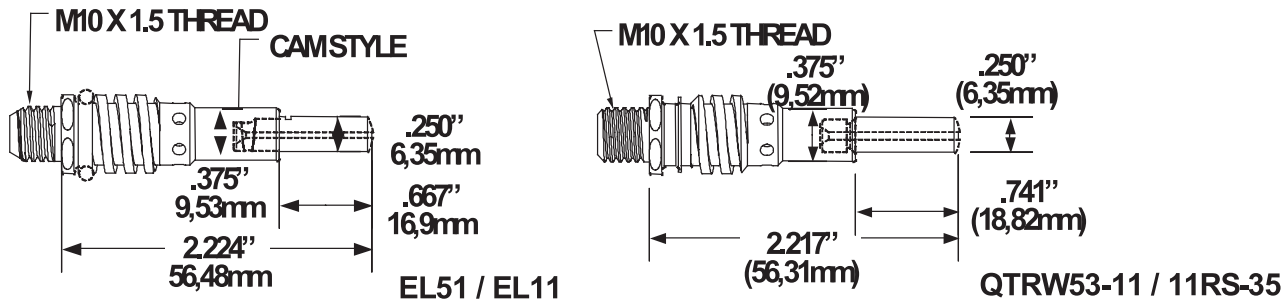

REL21 Nozzle Standard Tip Recess - .125" to .156" (3,17mm to 3,96mm)

| Bore Size | Part No. | Stock No. | A | B | C | D |
|--------------|----------|-----------|---------------|---------------|---------------|---------------|
| .500"/12,7mm | REL21-50 | 1210-1311 | .520"/13,21mm | .633"/16,08mm | .766"/19,46mm | .875"/22,23mm |

REL21 Nozzle Flush Tip Recess - Flush to .062" (1,57mm)

| Bore Size | Part No. | Stock No. | A | B | C | D |
|--------------|-----------|-----------|---------------|---------------|---------------|---------------|
| .500"/12,7mm | REL21-50F | 1210-1316 | .520"/13,21mm | .633"/16,08mm | .656"/16,66mm | .875"/22,23mm |

REL21 Nozzle Protruding Tip - .125" to .187" (3,17mm to 4,75mm)

| Bore Size | Part No. | Stock No. | A | B | C | D |
|--------------|-----------|-----------|---------------|---------------|---------------|---------------|
| .500"/12,7mm | REL21-50P | 1210-1321 | .520"/13,21mm | .633"/16,08mm | .466"/11,84mm | .875"/22,23mm |

