

STRAIGHT CUTTING TORCHES & CUTTING MACHINE REFERENCE GUIDE

Torch Model	Tip Usage	Fuel Gas Usage	Cut Capacity
"FC" Models			
ST 2600FC VanGuard™	Series 1	Any Fuel Gas	1/8" (3.2mm) to 8" (203.2mm)
ST 1000FC VanGuard	Series 1	Any Fuel Gas	1/8" (3.2mm) to 5" (127.0mm)
ST 900FC VanGuard	Series 1	Any Fuel Gas	1/8" (3.2mm) to 5" (127.0mm)
CST 800FC VanGuard	Series 3	Any Fuel Gas	1/8" (3.2mm) to 4" (101.6mm)
Machine Torches			
MT 200 (2 Hose)	Series 1	Any Fuel Gas	7" (177.8mm)
MT 300 (3 Hose)	Series 1	Any Fuel Gas	12" (304.8mm)
MT 1065 (3 Hose)	Series 1	Any Fuel Gas	7" (177.8mm)
MT 5 (3 Hose)	Series 1	Any Fuel Gas	7" (177.8mm)

CUTTING MACHINES

Torch Model	Tip Usage	Length	Circle
VCM 200 (Cutting Machine)	-	72" (182.9cm)	96" (243.8cm)

TIP TYPE: BTN FOR USE WITH NATURAL GAS & PROPANE. BTMP FOR USE WITH PROPYLENE GASES (FOR USE WITH MT200, MT300 SERIES MACHINE CUTTING TORCHES).

Length of Bevel	Tip Size	Speed IPM	Oxygen Pressure	Fuel Pressure	Cutting Oxygen Pressure
MT 200 Series					
1	4	10/18	60/75	8/10	-
1.5	4	8/16	60/75	8/10	-
2	4	6/14	60/75	8/10	-
2.5	4	5/12	60/75	8/10	-
3	5	6/11	60/75	8/12	-
3.5	5	5/10	60/75	8/12	-
4	5	4/9	60/75	8/12	-
4.5	5	4/8	60/75	8/12	-
5	6	3/8	65/85	8/15	-
5.5	6	3/7	65/85	8/15	-
6	6	3/6	65/85	8/15	-
MT 300N Series					
1	4	10/18	35/65	10/12	40/60
1.5	4	8/16	35/65	10/12	40/60
2	4	6/14	35/65	10/12	40/60
2.5	4	5/12	35/65	10/12	40/60
3	5	6/11	35/65	10/12	40/65
3.5	5	5/10	35/65	10/12	40/65
4	5	4/9	35/65	10/12	40/65
4.5	5	4/8	35/65	10/12	40/65
5	6	3/8	35/65	10/12	45/75
5.5	6	3/7	35/65	10/12	45/75
6	6	3/6	35/65	10/12	45/75

Bevels of 30° to 70° are possible on mild steel and most alloy steel without a preheat attachment.
High gas withdrawal rates will require manifolding. Consult your gas supplier.

Victor Machine Torches

They are available in two and three hose versions. Two hose torches are available in 4.5" (114.3mm), 10" (254.0mm) and 18" (457.2mm) models, and three hose torches are available in 10" (254.0mm) and 18" (457.2mm) models.

Check Valve - Pair Pak



The Check Valve
Prevents the reverse flow of gases.

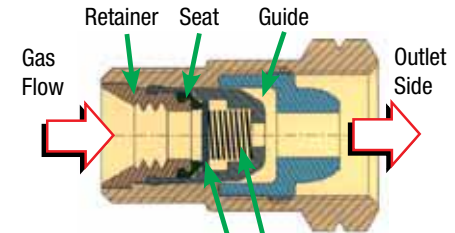

Disk assembly seals tight against seat in event of reverse flow.

Spring compresses under normal flow, moving disk assembly forward and allowing gas flow.

Accessory Reverse Flow Check Valves
Supplied with all machine torches for added operator safety

MT 200 Series
Two hose model

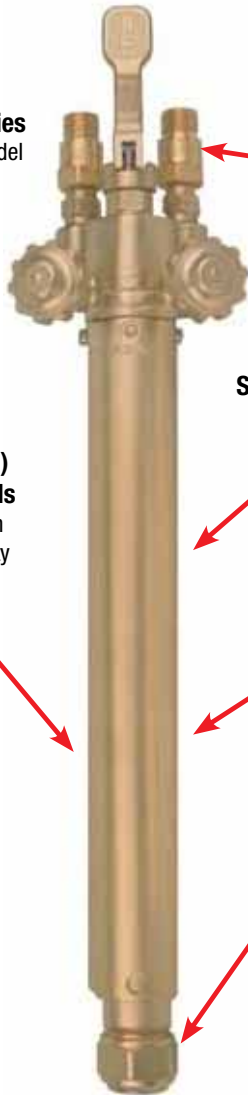

MT 300 Series
Three hose model

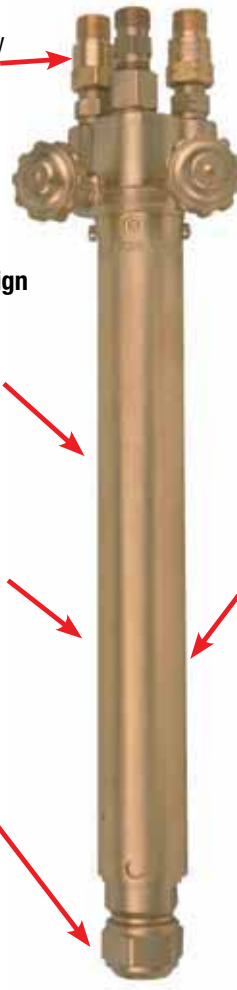

Pre-Drilled 1.38" (35.1mm) Diameter Barrels
For three position mounting flexibility

Straight Through Design
Minimizes turbulence, improves cutting performance

Pre-Drilled 1.38" (35.1mm) Diameter Barrels
For three position mounting flexibility

High Performance Mixer Design
Provide optimum performance

Rugged Brass
Torch head and body for maximum strength

Victor Professional

Victor machine cutting torches are available in two and three hose models. Three hose torches are high performance "straight through" design that minimizes turbulence and improves cut quality. Accessory reverse flow check valves are supplied for use at the torches inlet connection. All machine torches use Series 1 cutting tips and are supplied with accessory reverse flow check valves, to be used on the torch inlet connections. Supplied with rack soldered to barrel.

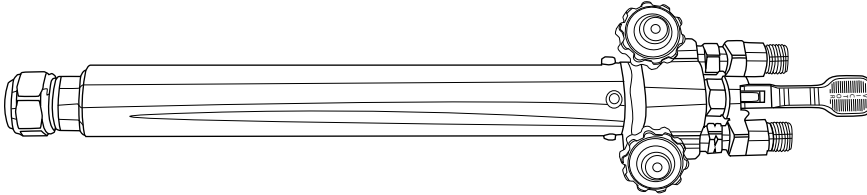

MT 200 Series (Two Hose)

- Cut capacity: 7" (177.8mm)
- Series 1 cutting tips

Part No.	Model No.	Total Length	Barrel Length	Racking Length	Gas
0380-0215	MT 204A	8.5" (215.9mm)	4.5" (114.3mm)	-	*Acetylene
0380-0217	MT 210A	14" (355.6mm)	10" (254.0mm)	7" (177.8mm)	*Acetylene
0380-0216	MT 210N	14" (355.6mm)	10" (254.0mm)	7" (177.8mm)	**LP/Natural Gas

*May also be used on other pressurized fuel gases.
 **May also be used on other fuel gases except acetylene
 Other machine torch models available. Ask for details.
Gear racks: Must be ordered separately.

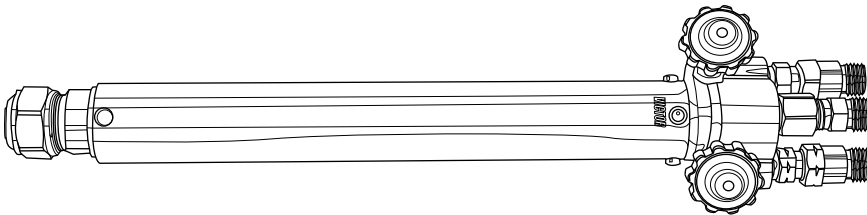

MT 300 Series (Three Hose)

- Cut capacity: 12" (304.8mm)
- Series 1 cutting tips

Part No.	Model No.	Total Length	Barrel Length	Racking Length	Gas
0380-0222	MT 310A	14" (355.6mm)	10" (254.0mm)	7" (177.8mm)	*Acetylene
0380-0220	MT 310N	14" (355.6mm)	10" (254.0mm)	7" (177.8mm)	**LP/Natural Gas
0380-0221	MT 310NV	14" (355.6mm)	10" (254.0mm)	7" (177.8mm)	**LP/Natural Gas
0380-0223	MT 310AV	14" (355.6mm)	10" (254.0mm)	7" (177.8mm)	*Acetylene
0380-0227	MT 318A	22.5" (571.5mm)	18" (457.2mm)	15" (381.0mm)	Acetylene
0380-0228	MT 318AV	22.5" (571.5mm)	18" (457.2mm)	15" (381.0mm)	*Acetylene
0380-0225	MT 318N	22.5" (571.5mm)	18" (457.2mm)	15" (381.0mm)	**LP/Natural Gas
0380-0226	MT 318NV	22.5" (571.5mm)	18" (457.2mm)	15" (381.0mm)	**LP/Natural Gas

*May also be used on other pressurized fuel gases.
 **May also be used on other fuel gases except acetylene
 Other machine torch models available. Ask for details.
Gear racks: Must be ordered separately.

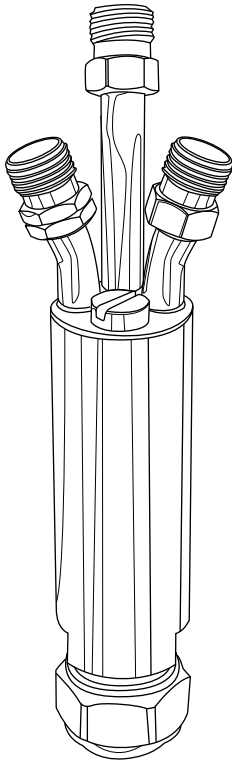

MT 1065 (Three Hose)

- Cut capacity: 7" (177.8mm)
- For use with all fuel gases
- Series 1 cutting tips
- Multi-torch beveling

Part No.	Model No.	Total Length	Barrel Dia.	Barrel Length	Racking Length	Gas
0399-1065	MT 1065N	8" (203.2mm)	1.25" (31.8mm)	4" (101.6mm)	-	All
0399-1121	MT 1065A	8" (203.2mm)	1.25" (31.8mm)	4" (101.6mm)	-	Acetylene

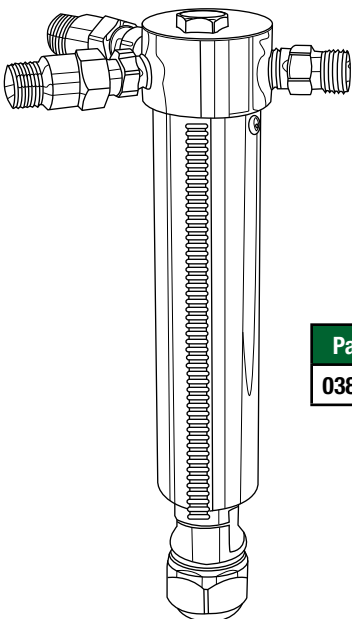

MT 5 (Three Hose)

- Cutting capacity - 7" (177.8mm)
- For use with any fuel gas 2 PSI and above
- Series 1 cutting tips

Part No.	Model No.	Total Length	Barrel Dia.	Barrel Length	Racking Length	Gas
0380-0208	MT 5	8.5" (215.9mm)	1.38" (35.1mm)	5.38" (136.7mm)	5.38" (136.7mm)	All

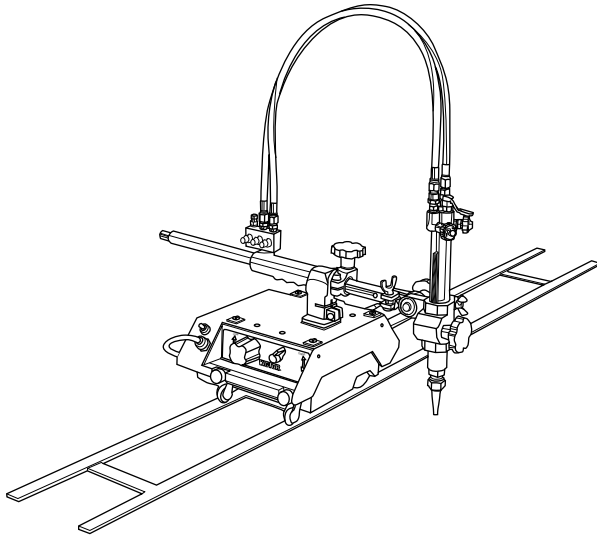

VCM 200 SERIES ORDERING INFORMATION

Model No.	Part No.	Speed Range/ Minute	Pkg. Includes
0200-0220	VCM 200	1-60" (25.4mm-152.4cm)	See Package Description #1
0200-0224	VCM 200HS	5-120" (127mm-304.8cm)	See Package Description #1
0200-0240	*VCM 200HT	1-60" (25.4mm-152.4cm)	See Package Description #1
0200-0221	VCM 201	1-60" (25.4mm-152.4cm)	See Package Description #2
0200-0225	VCM 201HS	5-120" (127mm-304.8cm)	See Package Description #2
0200-0241	*VCM 201HT	1-60" (25.4mm-152.4cm)	See Package Description #2

Export models available with 220V AC to 110V AC step down transformer.

*Models VCM-200 HT, VCM-201 HT, include heat shield.

ACCESSORY ORDERING INFORMATION

Part No.	Description
0212-0018	12' (3.7m) track section for line cutting
0212-0019	9' (2.7m) track section for line cutting
0212-0005	6' (1.8m) track section for line cutting
0252-0040	Radius rod for circle cutting
0253-0042	100" (254.0cm) radius rod for circle cutting
0252-0136	Dual torch mount assembly
0252-0103	Heat shield

VCM 200 Portable Cutting Machine

The versatile VCM 200 is a precision, tractor-type machine that can be used on its own track for straight line cutting and a variety of welding operations. Off track and with a radius rod assembly, the VCM 200 can be used for circle cutting.

- Large thumb screws for hand tight adjustments
- Dual drive controls & direct speed readout
- Cone disc drive
- Constant speed AC induction motor located on the side opposite the torch for cooler, more efficient operation
- Counter-balanced design allows torch racking distance up to 18" (457.2mm) from the machine
- Speed constant over wide range of temperatures
- Torch holder designed for 1.38" (35.1mm) barrel diameter torches

Package Description #1:

- Cutting machine
- MT 210A torch & torch rack
- Hoses & fittings (for 2 hose operation)
- 32 pitch pinion torch holder
- 3 hose manifold block

Package Description #2:

- Cutting machine
- Hoses & fittings (for 2 hose operation)
- 32 pitch pinion torch holder
- 3 hose manifold block

SPECIFICATIONS

Straight Line / Circle

- Length increments of 72" (182.9cm) (track length)
- Circle diameters 4" (101.6mm) to 96" (243.8cm)

Speed Range

- 1-60"/minute (25.4mm-152.4cm/minute)

Dimensions

- Length - 14.25" (362.0mm)
- Width - 11" (279.4mm)-machine only
28.5" (723.9mm)-machine & torch holder
- Height - 11.5" (292.1mm)-top of torch holder
5.5" (139.7mm)-top of machine
- Weight-Machine - 47 lb. (21kg)

VCM 200 HS (High Speed)

Has all the convenience and portability features of the standard VCM-200 machine, plus a speed range of 5-120"/min (12.7-304.8cm/min). The VCM-200HS has a flat mounting deck.

VCM 200 HT (High Temperature)

Same convenience, portability features and speed of the VCM-200 (Max. temp. 300°F), plus the addition of a heat shield.

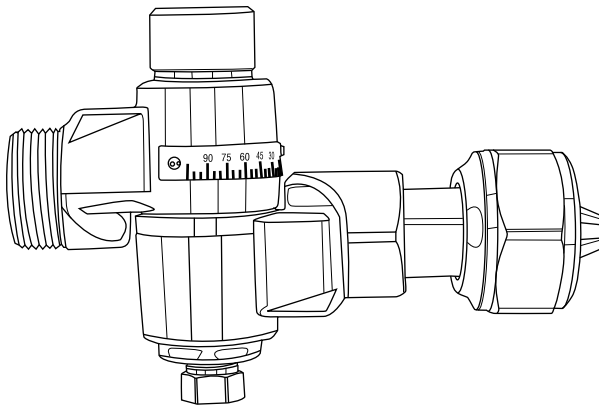

Model BHA 2

Model BHA 2 adjustable head adds flexibility to machine cutting torches by allowing bevel cuts without changing the position of the torch. It can be set at any angle from 0 to 90° on either side of vertical.

- Uses Series 1 cutting tips
- Optional preheat attachment is available for use with the BHA adjustable head attachment. The preheat attachment uses replaceable tip ends.

Part No.	Description
0383-0012	BHA 2
0304-0060	Preheating Attachment
Tip nut included (not shown).	

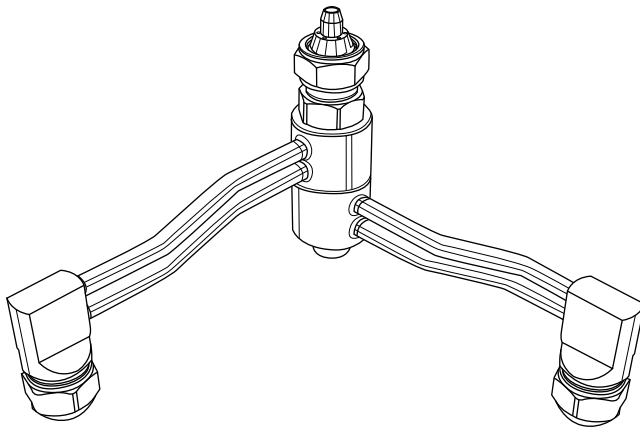

Model 591

Model 591 strip cutter for use with machine cutting torches only. It is designed to accept two tips for use with a common torch.

- Uses Series 1 cutting tips
- Adjustable for cutting strips from 1.25" (31.8mm) to 12" (304.8mm) wide, and thickness up to 3" (76.2mm).

Part No.	Description
0383-0000	591 Strip Cutter

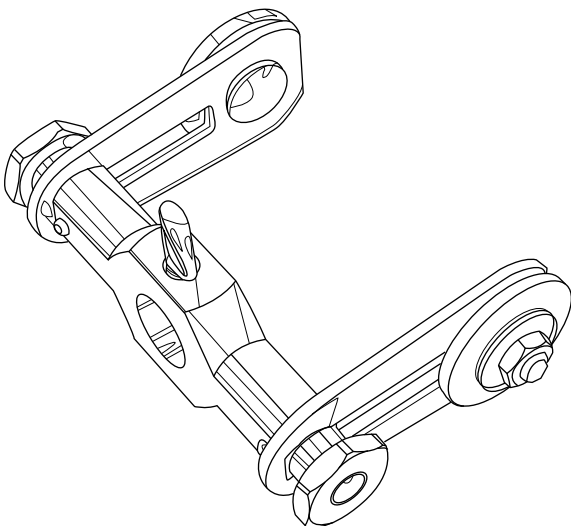

Model 497 Roller Guide

Model 497 roller guide is adaptable to most styles of cutting tips. Fits over the cutting tip shank and is fully adjustable for close, accurate work.

Part No.	Description
0383-0009	497 Roller Guide

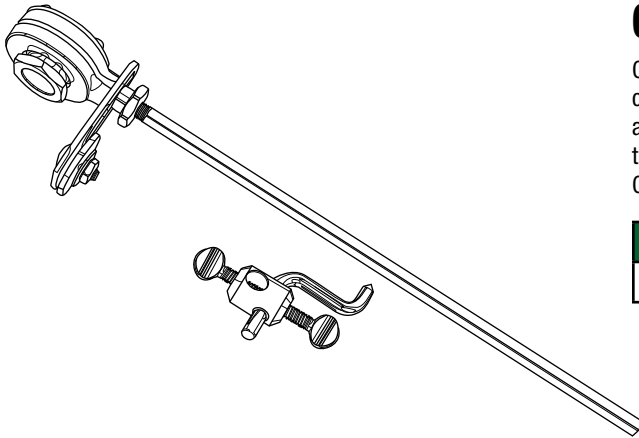

Circle Cutting Attachment

Circle Cutting Attachment is easily attached to a cutting torch or cutting attachment. The roller guide is adjustable to various heights and is designed to hold the cutting tip at exact pre-set distance from the work. Cutting range 1.5" (38.1mm) - 28" (71.1cm) circle.

Part No.	Description
0383-0006	D 496 Circle Cutting for Series 1 tips

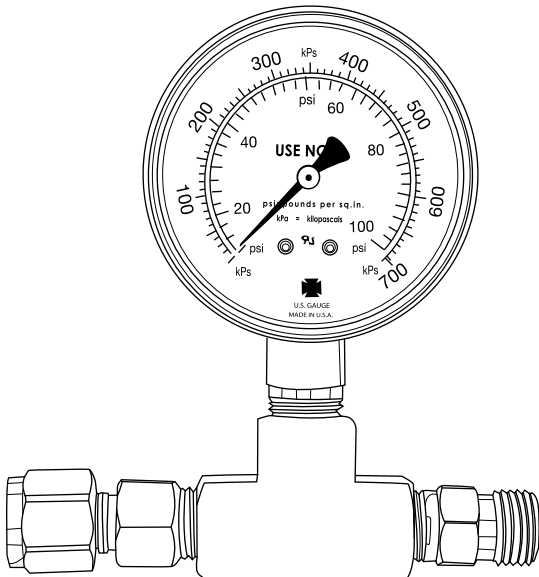

Test Gauges

For use when accurate line pressure is needed.

Part No.	Description
1420-0004	Oxygen, Model PD-10 100# Test, 2" (50.8mm) Dia. Gauge
1420-0003	Fuel Gas, Model PD-11 30# Test, 2" (50.8mm) Dia. Gauge



Gear Racks

For use with MT 200 and MT 300 Series cutting torches (must be ordered separately).

Part No.	Length	Pitch	Cutting Machine	Actual Length
0319-0054	10" (254.0mm) Rack Kit	32	MT 210 & MT 310	7.8" (198.1mm)
0319-0055	18" (457.2mm) Rack Kit	32	MT 318	14.5" (368.3mm)