

Fixed Automation Water-cooled Nozzle Assembly

Part No. 25WC-H (Stock No. 1250-1851)

Features:

- Provides water-cooled benefits to the front end of an air-cooled MIG gun.
- Ideal for welding application where heat build up on the standard air-cooled nozzle is extreme.
- Nozzle bore diameter is 3/4" (19,1mm)
- Easily installed on the TAM and RA Fixed Automation MIG guns or any style of conductor tube that has .625"x18 UNF-2B outside threads.
- Increase nozzle and front end consumable life.
- Supplied with nozzle, insulator, nut and water hoses (3 ft. - 91cm in length)

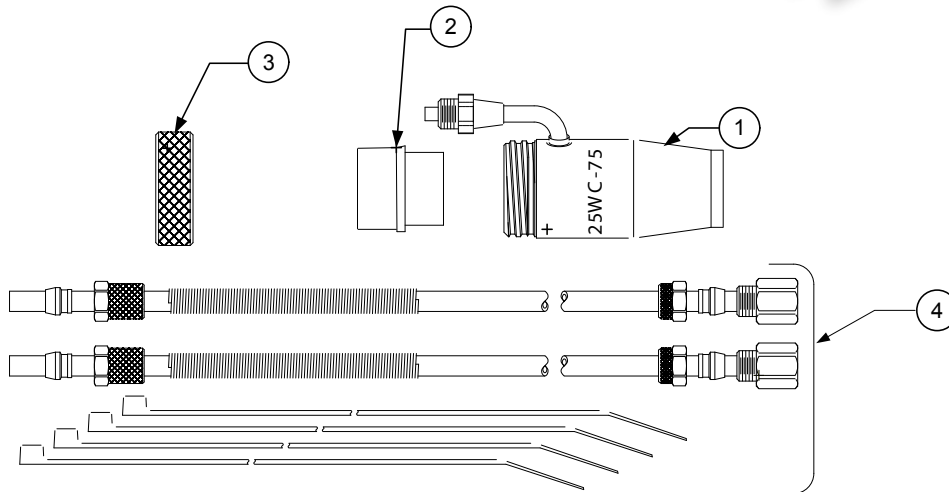

Replacement Parts

Item No.	Part No.	Stock No.	Description
1	25WC-75R	1250-1852	Water-cooled Nozzle Assembly
2	35WC	2050-2860	Nozzle Insulator
3	25SG-75-3	2050-2813	Nut
4	25WC-HK	2050-2852	Water-cooled Hose Kit (Includes 4 Nylon Ties)