

ITHERMAL ARC

A THERMADYNE® Company

SP-2001 Aluminum Spool Gun **SPC-2001 Control Module Box**



**SP-2001
Aluminum Spool Gun**

SP-2001 Spool Gun Features:

- 50ft./ 15.2m Leads Available
- Lightweight Torch
- Easy to Use Trigger
- Ideal for "Tough-To-Weld" Jobs
- Adjustable Wire Feed Speed at Gun



**SPC-2001
Control Module Box**

SPC-2001 Control Module Features:

- Two Models
 - 14 Pin amphenol for 24VAC Power Supplies with 25mm male dinse connector
 - 19 Pin amphenol for 115VAC Power Supplies
- Built-In Gas Solenoid and Gas Prewlow
- Quick Connection to Machines

APPLICATIONS:

Fabrication
Repair/Maintenance

Production Welding
Auto Body Shops

Vocational/Technical Schools
Trailer and Fleet Construction/ Repair

SP-2001 ALUMINUM SPOOL GUN

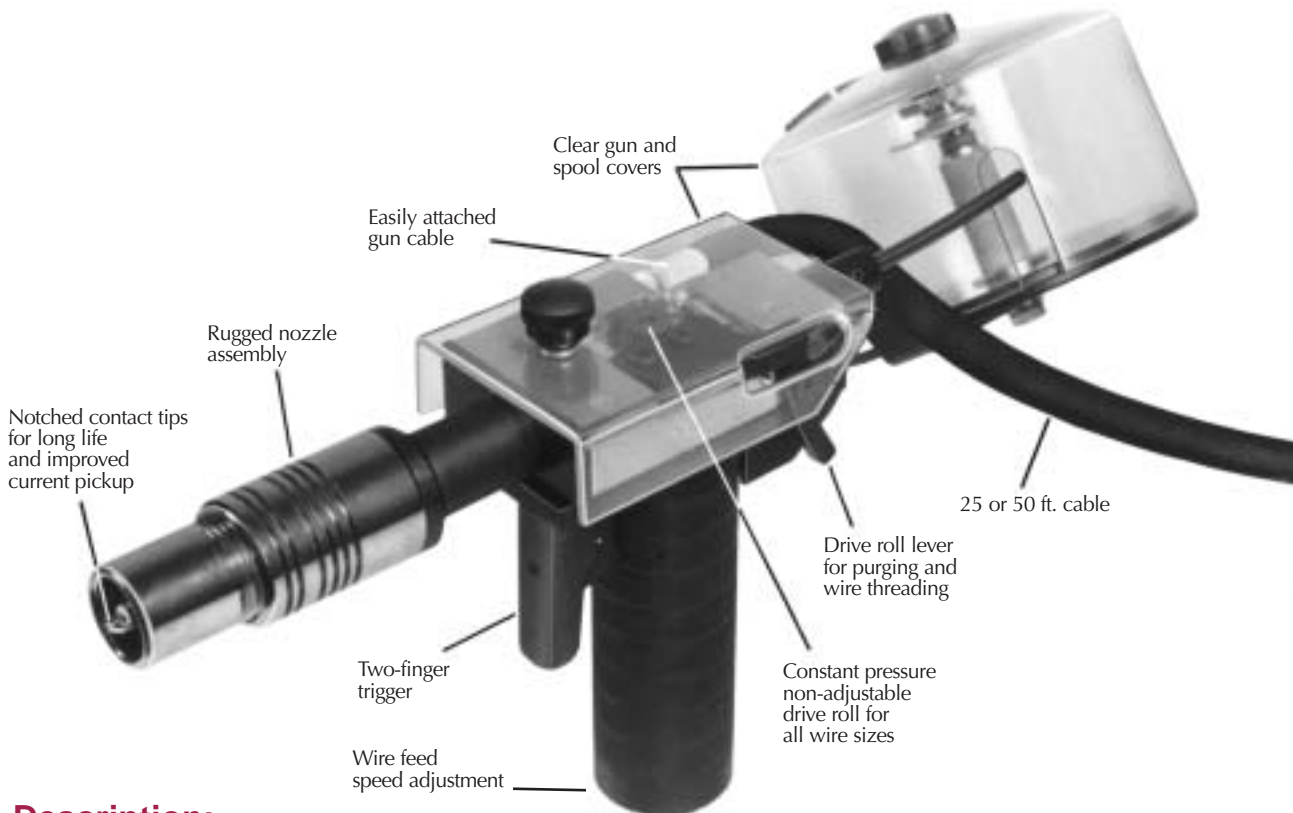

Description:

The SP-2001 spool gun is designed for .030"(.8mm), .035"(.9mm) and 3/64"(.12 diameter soft wire such as aluminum wire with argon as a shielding gas. The SP-2001 is out of the box Ready-To-Weld 3/64" diameter aluminum wire. (Six extra tips are included with the gun at no extra charge) Two different lead lengths allow this light weight gun to extended and reach up to 50ft. (15.2m) away from

the power source. The SP-2001 is the ideal gun for those "TOUGH - TO - WELD" jobs with adjustable nozzle and heavy duty front end parts. Advantages of a spool gun allows for the elimination of the wire feeding problems normally associated with feeding long distance and feedability of soft alloy wires such as aluminum in MIG guns with conventional cables.

SPC-2001 CONTROL MODULE BOX

The SPC-2001 control module box can operate on either CV or CC/CV power sources. The control module box controls both run-in speed and gas valve. The control module box is available to operate on power supplies with either 115VAC or 24VAC with output contactor.

To Order

SPC-2001 Control Module Box (Cat. No. 100013-002)

Includes 5ft. / (1.52m) welding power cable, 1/2" lug, 19 Pin amphenol contactor control cable, 6ft. / (1.8m). Operates on 115VAC input from power source contactor.

SPC-2001 Control Module Box (Cat. No. 100013-001)

Includes 5ft. / (1.52m) welding power cable, 25mm dinse connector, 14 Pin amphenol contactor control cable, 6ft. / (1.8m). Operates on 24VAC input from power source contactor.



SP-2001 NOZZLE ASSEMBLIES

HOW TO ORDER

SP-2001 Aluminum Spool Gun	
Length-25ft./(7.6m)	(Cat. No. 407838B-002)
Length-50ft./(15.2m)	(Cat. No. 407838B-001)

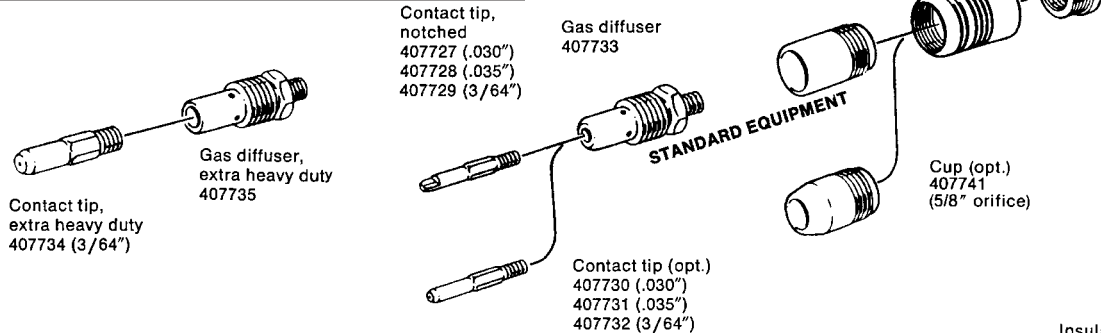

OPTIONAL FRONT END — ADJUSTABLE NOZZLE

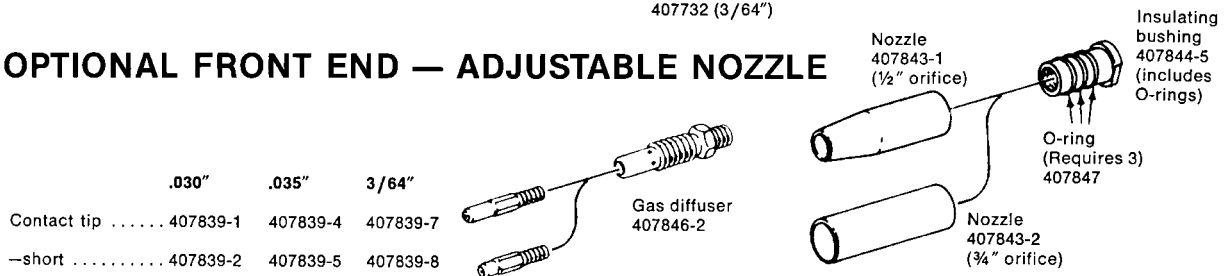

TYPICAL INSTALLATIONS

115VAC Model

Connecting the SP-2001 spool gun and SPC-2001 Control Module Box with Thermal Arc or competitive DC-CV or CC/CV power sources with 115VAC input from power source. Connect SPC-2001 Control Box Module to power supply and work lead with ground clamp to work piece.

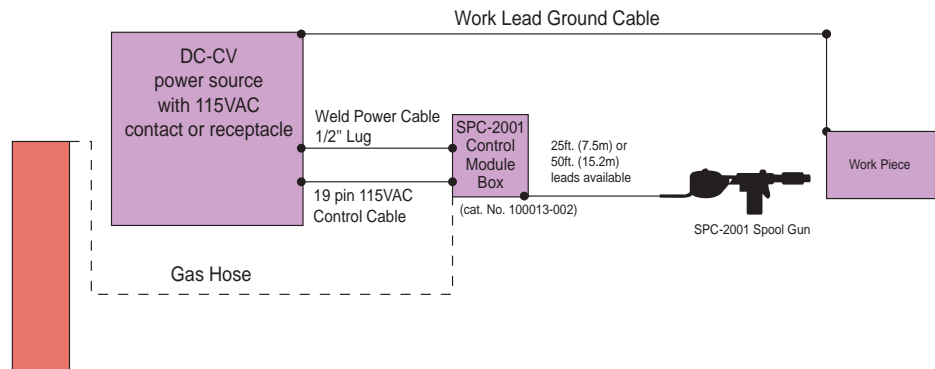

24VAC Model

Connecting the SP-2001 spool gun and SPC-2001 Control Module Box with Thermal Arc or competitive DC-CV or CC/CV power sources with 24VAC input from power source. Connect SPC-2001 Control Box Module to power supply and work lead with ground clamp to work piece.

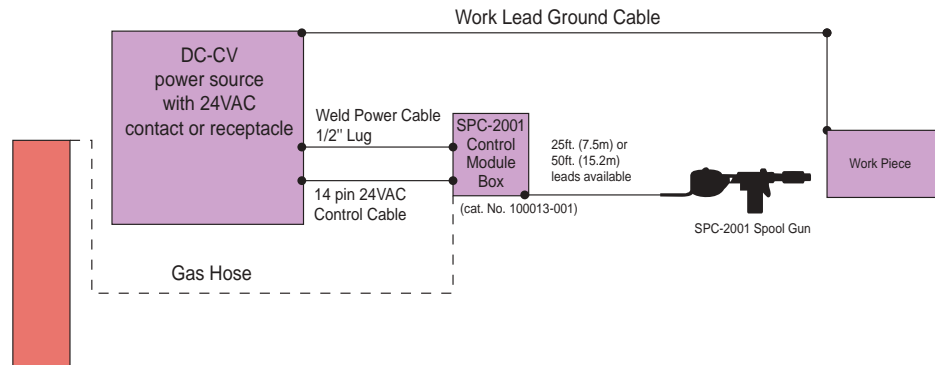

SP-2001 ALUMINUM SPOOL GUN

SP-2001 Spool Gun Specifications

Control Circuit Input:

Volts, AC 115 VAC or 24 VAC
 Phase..... 1ph
 Hertz Frequency 50/60 Hz
 Current..... 50 watts

Rating:

Amperes / Duty Cycle..... 250 amps / 60%
 Amperes / Duty Cycle..... 200 amps / 100%
 Wire Type..... Soft Alloys / Aluminum
 Wire Diameter Sizes..... .030" (.09mm)
 Reversible Roll035" (1.2mm) /
 3/64" (1.2mm)
 Wire Speed 50 to 650 IPM /
 1.3 16.5 m/min.

Current..... 50 watts

Weight:

Gun Body Only 2 3/4 lbs. / (1.2kg) (empty)
 Gun & 25 ft / (7.6m) lead.... 14 lbs. / (6.3kg)
 Gun & 50 ft. / (15m) lead.... 22 lbs. / (9.9kg)

HOW TO ORDER

SP-2001 Aluminum Spool Gun

Length-25ft./ (7.6) (Cat. No. 407838B-002)

Length-50ft./ (15.2) (Cat. No. 407838B-001)

DIMENSIONS:

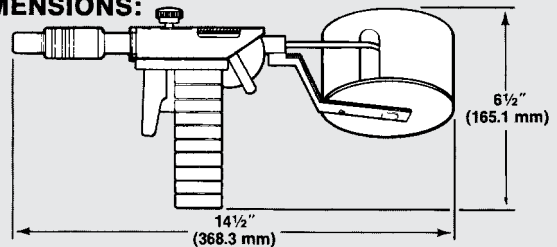

SPC-2001 CONTROL MODULE BOX

SPC-2001 CC/CV Control Box Module

Specifications

Fixed Preflow..... 2 seconds
 Fully adjustable slow run-in speed control
 Welding power cable, 5 ft. / (1.52m)
 Contactor control cable, 6ft. / (1.8m)
 Length:..... 8 1/2" / (216mm)
 Width:..... 5 3/4" / (146mm)
 Height with handle: 7.5" / (190mm)
 Weight:..... 12.5 lbs. / (5.6kg)

HOW TO ORDER

SPC-2001 Control Module Box (Cat. No. 100013-002)

Includes 5 ft. / (1.52m) welding power cable, 1/2" lug, 19 pin amphenol contactor control cable, 6 ft. / (1.8m)
 Operates on 115VAC input from power source.

SPC-2001 Control Module Box (Cat. No. 100013-001)

Includes 5 ft. / (1.52m) welding power cable, 25mm dinse connector, 14 pin amphenol contactor control cable, 6 ft. / (1.8m)
 Operates on 24VAC input from power source.

WORLD HEADQUARTERS: Suite 300, 16052 Swingley Ridge Road • St. Louis, MO 63017 • 636-728-3000



2200 Corporate Drive • Troy, OH 45373

CUSTOMER SERVICE: 800-255-5846 • FAX 800-332-0946



International Customer Service
 Oakville, Ontario, Canada
 Ph: (1) 905-827-9777
 Fax: (1) 905-827-9797

Thermadyne Canada
 Oakville, Ontario Canada
 Ph: (1) 905-827-1111
 Fax: (1) 905-827-3648

Thermadyne UK
 Chorley, England
 Ph: (44) 1257-261755
 Fax: (44) 1257-224800

Thermadyne Asia Sdn. Bhd.
 Kuala Lumpur, Malaysia
 Ph: (603) 6092-2988
 Fax: (603) 6092-1085

Cigweld Australia
 Melbourne, Australia
 Ph: (61) 3-9474-7400
 Fax: (61) 3-9474-7510

Unique Welding Alloys
 Johannesburg, South Africa
 Ph: (27) 11-917-3600
 Fax: (27) 11-917-8580

Thermadyne Victor Brasil
 Rio de Janeiro, Brazil
 Ph: (55) 21-2-485-8990
 Fax: (55) 21-2-485-8735

Thermadyne Middle East
 Dubai, United Arab Emirates
 Ph: (971) 4-332-9060
 Fax: (971) 4-332-5484

Thermadyne de Mexico
 Mexico City, Mexico
 Ph: (52) 55-5657-9494
 Fax: (52) 55-5648-8805

Thermadyne Japan
 Osaka, Japan
 Ph: (81) 6-4809-8411
 Fax: (81) 6-4809-8412

Thermadyne Italia
 Milan, Italy
 Ph: (39) 039-204-991
 Fax: (39) 039-204-9922

Thermadyne Chile
 Santiago, Chile
 Ph: (56) 2-557-2465
 Fax: (56) 2-557-5349