



WHY BUY  
**VICTOR**<sup>®</sup>  
**CutSkill**<sup>®</sup> ?

**VICTOR**<sup>®</sup>

# CUTSKILL 250



## Features

Quality Product Delivering Safety & Reliability,  
Premium Brand Name

Built to Victor's Specifications and Quality

Comprehensive Warranty

## Perfect for

Light to Medium Duty Applications

Frequent User



## WORLD LEADER IN GAS APPARATUS AND PRESSURE CONTROL

Victor Equipment Company, founded in 1913, is the leading manufacturer of gas apparatus. Committed to providing you superior quality, reliable products and safe, reliable performance.

**VICTOR**<sup>®</sup>  
**CutSkill**<sup>®</sup>



- ✓ SAFETY
- ✓ PERFORMANCE
- ✓ DURABILITY

**VICTOR**<sup>®</sup>  
CutSkill<sup>®</sup>

# SAFETY

We understand that a job well done is important. But we also understand that working safely is important to you and your family. That's why Victor Cutskill has patented safety features built-in to the torch handles in all Victor outfits.

## There's No Substitute For Victor Built-In Safety

## VICTOR CUTSKILL 250 HANDLE

Hose connection housing threaded into back body block - easily replaced

Replaceable built-in reverse flow check valves

Replaceable built-in flashback arrestors

Threaded inner and outer tube design

Heavy inner and outer tube design

Threaded and compression design

Large flow orifices

### A NEW DIMENSION IN OPERATOR SAFETY!

Victor Torch Handles are available with VanGuard™ safety features:

- Built-In Flashback Arrestors
- Built-in Reverse Flow Check Valves
- Therefore there is never a need for accessory reverse flow check valves or accessory flash arrestors.

VanGuard™ Torch Handles are offered in Heavy-Duty and Medium-Duty models, and available in all of Victor's outfits. VanGuard™ Torch Handles also feature Victor Traditional threaded assemblies for quick economical repair if service is necessary.

# COMPARE TO...

## HARRIS CALORIFIC'S STEELWORKER HANDLE

Harris Calorific's Steelworker Handle does not include built-in check valves or flash arrestors. These features are designed into every Victor Cutskill handle. Your safety is our highest priority.

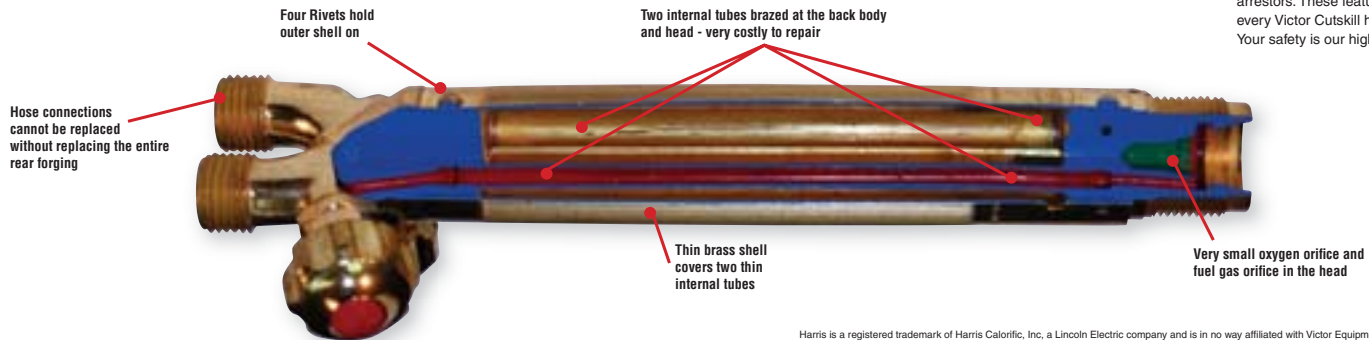

**VICTOR**<sup>®</sup>  
CutSkill<sup>®</sup>

# PERFORMANCE

Field proven since 1913, Victor continues to set the industry standard that can only be imitated, but never matched. Every piece from tips to regulators is built to handle the toughest, most demanding job sites. And now, every component is housed in an attractive toolbox that keeps your outfit protected and organized.

## Built-In Performance

## VICTOR CUTSKILL 250 CUTTING ATTACHMENT

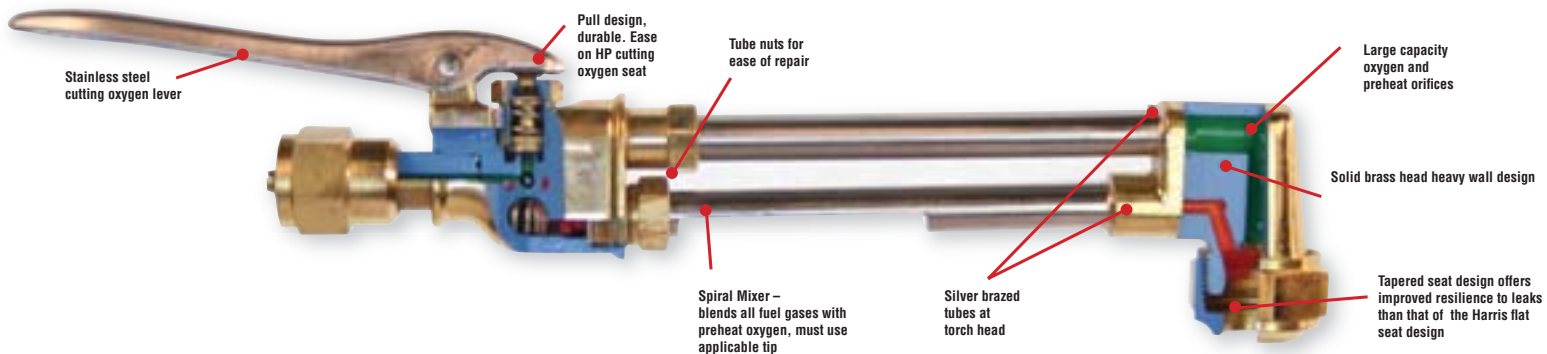

# COMPARE TO...

## HARRIS CALORIFIC'S STEELWORKER CUTTING ATTACHMENT

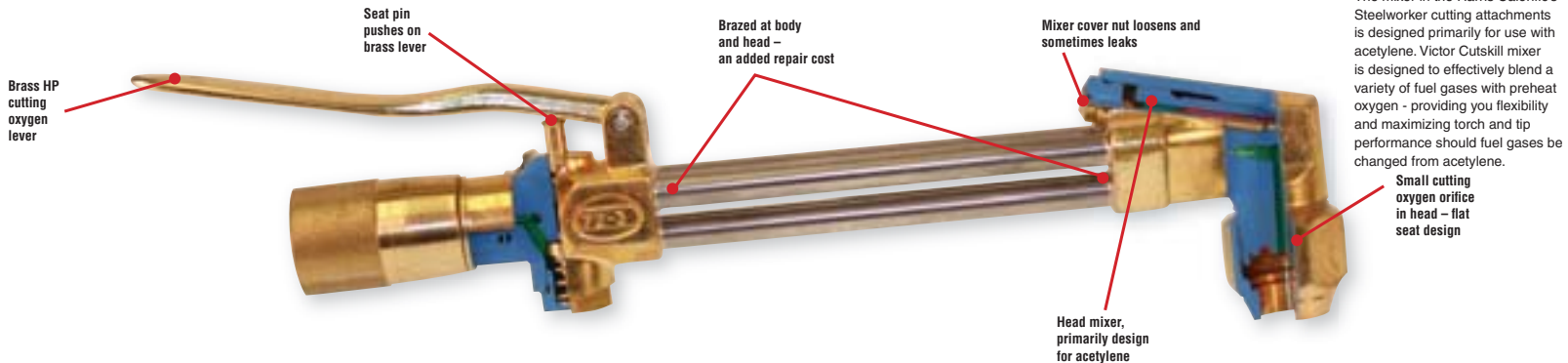

**VICTOR**<sup>®</sup>  
CutSkill<sup>®</sup>

# DURABILITY

Every day since 1913, VICTOR has continued to earn its reputation as the premium designer and manufacturer of oxy fuel welding and cutting apparatus systems. Used around the world in the most extreme conditions, VICTOR regulators and torches are built to take the pressure with the durability features that set the industry standard.

## Heavy-Duty Design And Construction Features

## VICTOR CUTSKILL 250 REGULATOR

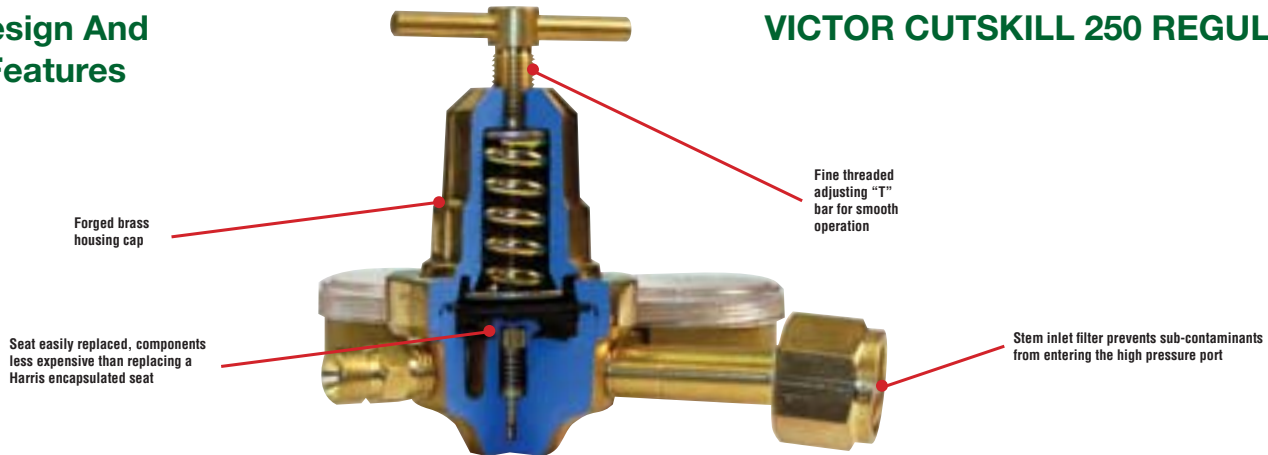

# COMPARE TO...

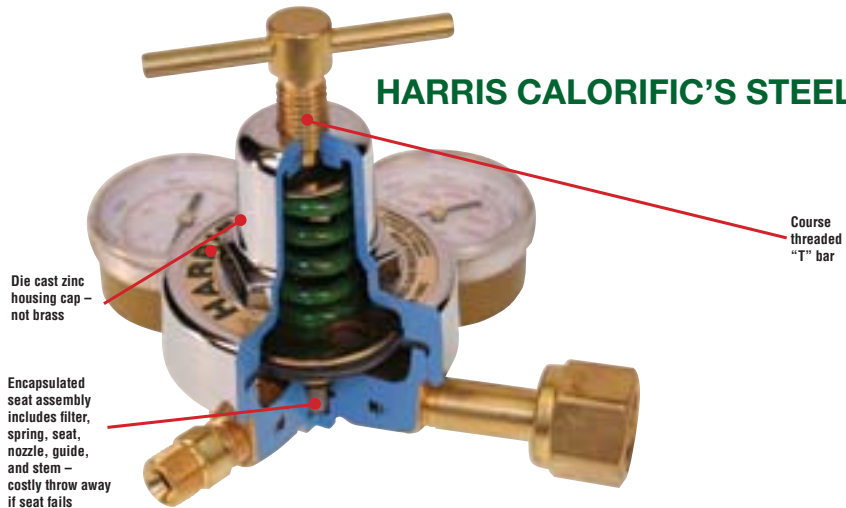

## HARRIS CALORIFIC'S STEELWORKER REGULATOR

Die cast zinc housing cap – not brass

Course threaded "T" bar

Encapsulated seat assembly includes filter, spring, seat, nozzle, guide, and stem – costly throw away if seat fails

**VICTOR**<sup>®</sup>  
CutSkill<sup>®</sup>

# CHOICE

Even when considering Victor's Cutskill outfits you have several choices. Each is modeled after the Victor Professional Series. Cutskill is designed and manufactured to serve you with enhanced safety, durability and performance over competitive models.

## Component Matched To Your Exact Needs



**Cutskill 250: Medium Duty**



**Cutskill 350: Heavy/Medium Duty**



**Cutskill 450: Heavy Duty**



**Cutskill PortableTote™: Light Duty**

**VICTOR**<sup>®</sup>  
CutSkill<sup>®</sup>

# SELECTION

VICTOR's got it when it comes to a full line of outfits, torches, regulators, flowmeters and interchangeable tips; including multifuel gas cutting, welding, brazing, heating and specialty torch tips. See your local VICTOR distributor.



**Regulators**



**Accessory Tips**



**Handles**



**Cutting Tips**



**Cutting Attachments**



**Available Outfits**

***VICTOR***®  
***CutSkill***®  
**www.victorequip.com**