

THERMAL DYNAMICS[®]



A THERMADYNE[®] Company

ECONO-PAK 50

Air Plasma Cutting Power Supply

The System Includes:

- ***ECONO-PAK 50 Power Supply***
- ***PCH-26 Torch with Leads***
- ***Work Cable with Clamp***

Operating Manual

September 1, 1998

Manual No. 0-2450

**WARNING**

Read and understand this entire Operating Manual and your employer's safety practices before installing, operating, or servicing the equipment.

**WARNING**

While the information contained in this Operating Manual represents our best judgement, Thermal Dynamics Corporation assumes no liability for its use.

Econo-Pak 50 Air Plasma Cutting Power Supply
Operating Manual Number 0-2450

Published by:

Thermal Dynamics Corporation
Industrial Park No. 2
West Lebanon, New Hampshire, USA 03784
(603) 298-5711

Copyright 1997 by
Thermal Dynamics Corporation

All rights reserved.

Reproduction of this work, in whole or in part, without written permission of the publisher is prohibited.

The publisher does not assume and hereby disclaims any liability to any party for any loss or damage caused by any error or omission in the Econo-Pak 50 Air Plasma Cutting Power Supply Operating Manual, whether such error results from negligence, accident, or any other cause.

Printed in the United States of America

September 1, 1998

RECORD SERIAL NUMBERS FOR WARRANTY PURPOSES

Purchase Date

Power Supply

Torch

TABLE OF CONTENTS

SECTION 1: GENERAL INFORMATION	1
1.01 Notes, Cautions and Warnings	1
1.02 Important Safety Precautions	1
1.03 Publications	2
1.04 Note, Attention et Avertissement	3
1.05 Precautions De Securite Importantes	3
1.06 Documents De Reference	5
1.07 Declaration of Conformity	6
1.08 Statement of Warranty	7
SECTION 2: INTRODUCTION & DESCRIPTION	9
2.01 SYSTEM SPECIFICATIONS	9
2.02 TORCH PARTS.....	10
SECTION 3: INSTALLATION	11
3.01 UNPACKING AND CHOOSING A LOCATION	11
3.02 ELECTRICAL CONNECTIONS	11
3.03 GAS CONNECTIONS	12
3.03 GAS CONNECTIONS (Continued)	13
SECTION 4: OPERATION	15
4.01 OPERATING CONTROLS	15
4.02 GETTING STARTED	16
4.03 OPERATING THE SYSTEM	17
4.03 OPERATING THE SYSTEM (continued)	18
4.04 OPERATING WITH A HAND TORCH	19
4.05 RECOMMENDED CUTTING SPEEDS	20
SECTION 5: CUSTOMER/OPERATOR SERVICE	21
5.01 TROUBLESHOOTING AND MAINTENANCE	21
5.02 BASIC TROUBLESHOOTING GUIDE	22
5.03 REPLACING CONSUMABLE TORCH PARTS	23
SECTION 6: PARTS LISTS.....	25
6.01 INTRODUCTION	25
6.02 REPLACEMENT - COMPLETE SYSTEMS	26
6.03 REPLACEMENT TORCH AND LEAD ASSEMBLIES	27
6.04 OPTIONS AND ACCESSORIES	28
6.05 REPLACEMENT HAND TORCH PARTS	29
This Page Left Blank	31
APPENDIX I: SYSTEM SCHEMATIC.....	32

SECTION 1: GENERAL INFORMATION

1.01 Notes, Cautions and Warnings

Throughout this manual, notes, cautions, and warnings are used to highlight important information. These highlights are categorized as follows:

NOTE

An operation, procedure, or background information which requires additional emphasis or is helpful in efficient operation of the system.

CAUTION

A procedure which, if not properly followed, may cause damage to the equipment.



WARNING

A procedure which, if not properly followed, may cause injury to the operator or others in the operating area.

1.02 Important Safety Precautions



WARNING

OPERATION AND MAINTENANCE OF PLASMA ARC EQUIPMENT CAN BE DANGEROUS AND HAZARDOUS TO YOUR HEALTH.

To prevent possible injury, read, understand and follow all warnings, safety precautions and instructions before using the equipment. Call 1-603-298-5711 or your local distributor if you have any questions.



GASES AND FUMES

Gases and fumes produced during the plasma cutting process can be dangerous and hazardous to your health.

- Keep all fumes and gases from the breathing area. Keep your head out of the welding fume plume.

- Use an air-supplied respirator if ventilation is not adequate to remove all fumes and gases.
- The kinds of fumes and gases from the plasma arc depend on the kind of metal being used, coatings on the metal, and the different processes. You must be very careful when cutting or welding any metals which may contain one or more of the following:

Antimony	Chromium	Mercury
Arsenic	Cobalt	Nickel
Barium	Copper	Selenium
Beryllium	Lead	Silver
Cadmium	Manganese	Vanadium

- Always read the Material Safety Data Sheets (MSDS) that should be supplied with the material you are using. These MSDSs will give you the information regarding the kind and amount of fumes and gases that may be dangerous to your health.
- For information on how to test for fumes and gases in your workplace, refer to item 1 in Subsection 1.03, Publications in this manual.
- Use special equipment, such as water or down draft cutting tables, to capture fumes and gases.
- Do not use the plasma torch in an area where combustible or explosive gases or materials are located.
- Phosgene, a toxic gas, is generated from the vapors of chlorinated solvents and cleansers. Remove all sources of these vapors.



ELECTRIC SHOCK

Electric Shock can injure or kill. The plasma arc process uses and produces high voltage electrical energy. This electric energy can cause severe or fatal shock to the operator or others in the workplace.

- Never touch any parts that are electrically “live” or “hot.”
- Wear dry gloves and clothing. Insulate yourself from the work piece or other parts of the welding circuit.
- Repair or replace all worn or damaged parts.
- Extra care must be taken when the workplace is moist or damp.
- Install and maintain equipment according to NEC code, refer to item 9 in Subsection 1.03, Publications.
- Disconnect power source before performing any service or repairs.
- Read and follow all the instructions in the Operating Manual.



FIRE AND EXPLOSION

Fire and explosion can be caused by hot slag, sparks, or the plasma arc.

- Be sure there is no combustible or flammable material in the workplace. Any material that cannot be removed must be protected.
- Ventilate all flammable or explosive vapors from the workplace.
- Do not cut or weld on containers that may have held combustibles.
- Provide a fire watch when working in an area where fire hazards may exist.
- Hydrogen gas may be formed and trapped under aluminum workpieces when they are cut underwater or while using a water table. **DO NOT** cut aluminum alloys underwater or on a water table unless the hydrogen gas can be eliminated or dissipated. Trapped hydrogen gas that is ignited will cause an explosion.



NOISE

Noise can cause permanent hearing loss. Plasma arc processes can cause noise levels to exceed safe limits. You must protect your ears from loud noise to prevent permanent loss of hearing.

- To protect your hearing from loud noise, wear protective ear plugs and/or ear muffs. Protect others in the workplace.
- Noise levels should be measured to be sure the decibels (sound) do not exceed safe levels.
- For information on how to test for noise, see item 1 in Subsection 1.03, Publications, in this manual.



PLASMA ARC RAYS

Plasma Arc Rays can injure your eyes and burn your skin. The plasma arc process produces very bright ultra violet and infra red light. These arc rays will damage your eyes and burn your skin if you are not properly protected.

- To protect your eyes, always wear a welding helmet or shield. Also always wear safety glasses with side shields, goggles or other protective eye wear.
- Wear welding gloves and suitable clothing to protect your skin from the arc rays and sparks.
- Keep helmet and safety glasses in good condition. Replace lenses when cracked, chipped or dirty.

- Protect others in the work area from the arc rays. Use protective booths, screens or shields.
- Use the shade of lens as recommended in Subsection 1.03, item 4.

1.03 Publications

Refer to the following standards or their latest revisions for more information:

1. OSHA, SAFETY AND HEALTH STANDARDS, 29CFR 1910, obtainable from the Superintendent of Documents, U.S. Government Printing Office, Washington, D.C. 20402
2. ANSI Standard Z49.1, SAFETY IN WELDING AND CUTTING, obtainable from the American Welding Society, 550 N.W. LeJeune Rd, Miami, FL 33126
3. NIOSH, SAFETY AND HEALTH IN ARC WELDING AND GAS WELDING AND CUTTING, obtainable from the Superintendent of Documents, U.S. Government Printing Office, Washington, D.C. 20402
4. ANSI Standard Z87.1, SAFE PRACTICES FOR OCCUPATION AND EDUCATIONAL EYE AND FACE PROTECTION, obtainable from American National Standards Institute, 1430 Broadway, New York, NY 10018
5. ANSI Standard Z41.1, STANDARD FOR MEN'S SAFETY-TOE FOOTWEAR, obtainable from the American National Standards Institute, 1430 Broadway, New York, NY 10018
6. ANSI Standard Z49.2, FIRE PREVENTION IN THE USE OF CUTTING AND WELDING PROCESSES, obtainable from American National Standards Institute, 1430 Broadway, New York, NY 10018
7. AWS Standard A6.0, WELDING AND CUTTING CONTAINERS WHICH HAVE HELD COMBUSTIBLES, obtainable from American Welding Society, 550 N.W. LeJeune Rd, Miami, FL 33126
8. NFPA Standard 51, OXYGEN-FUEL GAS SYSTEMS FOR WELDING, CUTTING AND ALLIED PROCESSES, obtainable from the National Fire Protection Association, Batterymarch Park, Quincy, MA 02269
9. NFPA Standard 70, NATIONAL ELECTRICAL CODE, obtainable from the National Fire Protection Association, Batterymarch Park, Quincy, MA 02269
10. NFPA Standard 51B, CUTTING AND WELDING PROCESSES, obtainable from the National Fire Protection Association, Batterymarch Park, Quincy, MA 02269
11. CGA Pamphlet P-1, SAFE HANDLING OF COMPRESSED GASES IN CYLINDERS, obtainable from the Compressed Gas Association, 1235 Jefferson Davis Highway, Suite 501, Arlington, VA 22202

12. CSA Standard W117.2, CODE FOR SAFETY IN WELDING AND CUTTING, obtainable from the Canadian Standards Association, Standards Sales, 178 Rexdale Boulevard, Rexdale, Ontario, Canada M9W 1R3
13. NWSA booklet, WELDING SAFETY BIBLIOGRAPHY obtainable from the National Welding Supply Association, 1900 Arch Street, Philadelphia, PA 19103
14. American Welding Society Standard AWSF4.1, RECOMMENDED SAFE PRACTICES FOR THE PREPARATION FOR WELDING AND CUTTING OF CONTAINERS AND PIPING THAT HAVE HELD HAZARDOUS SUBSTANCES, obtainable from the American Welding Society, 550 N.W. LeJeune Rd, Miami, FL 33126
15. ANSI Standard Z88.2, PRACTICE FOR RESPIRATORY PROTECTION, obtainable from American National Standards Institute, 1430 Broadway, New York, NY 10018

1.04 Note, Attention et Avertissement

Dans ce manuel, les mots “note,” “attention,” et “avertissement” sont utilisés pour mettre en relief des informations à caractère important. Ces mises en relief sont classifiées comme suit :

NOTE

Toute opération, procédure ou renseignement général sur lequel il importe d'insister davantage ou qui contribue à l'efficacité de fonctionnement du système.

ATTENTION

Toute procédure pouvant résulter l'endommagement du matériel en cas de non-respect de la procédure en question.



AVERTISSEMENT

Toute procédure pouvant provoquer des blessures de l'opérateur ou des autres personnes se trouvant dans la zone de travail en cas de non-respect de la procédure en question.

1.05 Precautions De Securite Importantes



AVERTISSEMENT

L'OPÉRATION ET LA MAINTENANCE DU MATÉRIEL DE SOUDAGE À L'ARC AU JET DE PLASMA PEUVENT PRÉSENTER DES RISQUES ET DES DANGERS DE SANTÉ.

Il faut communiquer aux opérateurs et au personnel TOUS les dangers possibles. Afin d'éviter les blessures possibles, lisez, comprenez et suivez tous les avertissements, toutes les précautions de sécurité et toutes les consignes avant d'utiliser le matériel. Composez le + 603-298-5711 ou votre distributeur local si vous avez des questions.



FUMÉE et GAZ

La fumée et les gaz produits par le procédé de jet de plasma peuvent présenter des risques et des dangers de santé.

- Eloignez toute fumée et gaz de votre zone de respiration. Gardez votre tête hors de la plume de fumée provenant du chalumeau.
- Utilisez un appareil respiratoire à alimentation en air si l'aération fournie ne permet pas d'éliminer la fumée et les gaz.
- Les sortes de gaz et de fumée provenant de l'arc de plasma dépendent du genre de métal utilisé, des revêtements se trouvant sur le métal et des différents procédés. Vous devez prendre soin lorsque vous coupez ou soudez tout métal pouvant contenir un ou plusieurs des éléments suivants:

antimoine	cadmium	mercure
argent	chrome	nickel
arsenic	cobalt	plomb
baryum	cuivre	sélénium
béryllium	manganèse	vanadium
- Lisez toujours les fiches de données sur la sécurité des matières (sigle américain “MSDS”); celles-ci devraient être fournies avec le matériel que vous utilisez. Les MSDS contiennent des renseignements quant à la quantité et la nature de la fumée et des gaz pouvant poser des dangers de santé.
- Pour des informations sur la manière de tester la fumée et les gaz de votre lieu de travail, consultez l'article 1 et les documents cités à la page 5.

- Utilisez un équipement spécial tel que des tables de coupe à débit d'eau ou à courant descendant pour capter la fumée et les gaz.
- N'utilisez pas le chalumeau au jet de plasma dans une zone où se trouvent des matières ou des gaz combustibles ou explosifs.
- Le phosgène, un gaz toxique, est généré par la fumée provenant des solvants et des produits de nettoyage chlorés. Éliminez toute source de telle fumée.



CHOC ELECTRIQUE

Les chocs électriques peuvent blesser ou même tuer. Le procédé au jet de plasma requiert et produit de l'énergie électrique haute tension. Cette énergie électrique peut produire des chocs graves, voire mortels, pour l'opérateur et les autres personnes sur le lieu de travail.

- Ne touchez jamais une pièce "sous tension" ou "vive"; portez des gants et des vêtements secs. Isolez-vous de la pièce de travail ou des autres parties du circuit de soudage.
- Réparez ou remplacez toute pièce usée ou endommagée.
- Prenez des soins particuliers lorsque la zone de travail est humide ou moite.
- Montez et maintenez le matériel conformément au Code électrique national des Etats-Unis. (Voir la page 5, article 9.)
- Débranchez l'alimentation électrique avant tout travail d'entretien ou de réparation.
- Lisez et respectez toutes les consignes du Manuel de consignes.



INCENDIE ET EXPLOSION

Les incendies et les explosions peuvent résulter des scories chaudes, des étincelles ou de l'arc de plasma. Le procédé à l'arc de plasma produit du métal, des étincelles, des scories chaudes pouvant mettre le feu aux matières combustibles ou provoquer l'explosion de fumées inflammables.

- Soyez certain qu'aucune matière combustible ou inflammable ne se trouve sur le lieu de travail. Protégez toute telle matière qu'il est impossible de retirer de la zone de travail.
- Procurez une bonne aération de toutes les fumées inflammables ou explosives.
- Ne coupez pas et ne soudez pas les conteneurs ayant pu renfermer des matières combustibles.

- Prévoyez une veille d'incendie lors de tout travail dans une zone présentant des dangers d'incendie.
- Le gas hydrogène peut se former ou s'accumuler sous les pièces de travail en aluminium lorsqu'elles sont coupées sous l'eau ou sur une table d'eau. NE PAS couper les alliages en aluminium sous l'eau ou sur une table d'eau à moins que le gas hydrogène peut s'échapper ou se dissiper. Le gas hydrogène accumulé explosera si enflammé.



RAYONS D'ARC DE PLASMA

Les rayons provenant de l'arc de plasma peuvent blesser vos yeux et brûler votre peau. Le procédé à l'arc de plasma produit une lumière infra-rouge et des rayons ultra-violets très forts. Ces rayons d'arc nuiront à vos yeux et brûleront votre peau si vous ne vous protégez pas correctement.

- Pour protéger vos yeux, portez toujours un casque ou un écran de soudeur. Portez toujours des lunettes de sécurité munies de parois latérales ou des lunettes de protection ou une autre sorte de protection oculaire.
- Portez des gants de soudeur et un vêtement protecteur approprié pour protéger votre peau contre les étincelles et les rayons de l'arc.
- Maintenez votre casque et vos lunettes de protection en bon état. Remplacez toute lentille sale ou comportant fissure ou rognure.
- Protégez les autres personnes se trouvant sur la zone de travail contre les rayons de l'arc en fournissant des cabines ou des écrans de protection.
- Respectez le teint de lentille recommandé dans le article 4, page 5.



BRUIT

Le bruit peut provoquer une perte permanente de l'ouïe. Les procédés de soudage à l'arc de plasma peuvent provoquer des niveaux sonores supérieurs aux limites normalement acceptables. Vous devez vous protéger les oreilles contre les bruits forts afin d'éviter une perte permanente de l'ouïe.

- Pour protéger votre ouïe contre les bruits forts, portez des tampons protecteurs et/ou des protections auriculaires. Protégez également les autres personnes se trouvant sur le lieu de travail.
- Il faut mesurer les niveaux sonores afin d'assurer que les décibels (le bruit) ne dépassent pas les niveaux sûrs.

- Pour des renseignements sur la manière de tester le bruit, consultez l'article 1, page 5.

1.06 Documents De Reference

Consultez les normes suivantes ou les révisions les plus récentes ayant été faites à celles-ci pour de plus amples renseignements :

1. OSHA, NORMES DE SÉCURITÉ DU TRAVAIL ET DE PROTECTION DE LA SANTÉ, 29CFR 1910, disponible auprès du Superintendent of Documents, U.S. Government Printing Office, Washington, D.C. 20402
2. Norme ANSI Z49.1, LA SÉCURITÉ DES OPÉRATIONS DE COUPE ET DE SOUDAGE, disponible auprès de la Société Américaine de Soudage (American Welding Society), 550 N.W. LeJeune Rd., Miami, FL 33126
3. NIOSH, LA SÉCURITÉ ET LA SANTÉ LORS DES OPÉRATIONS DE COUPE ET DE SOUDAGE À L'ARC ET AU GAZ, disponible auprès du Superintendent of Documents, U.S. Government Printing Office, Washington, D.C. 20402
4. Norme ANSI Z87.1, PRATIQUES SURES POUR LA PROTECTION DES YEUX ET DU VISAGE AU TRAVAIL ET DANS LES ECOLES, disponible de l'Institut Américain des Normes Nationales (American National Standards Institute), 1430 Broadway, New York, NY 10018
5. Norme ANSI Z41.1, NORMES POUR LES CHAUSSURES PROTECTRICES, disponible auprès de l'American National Standards Institute, 1430 Broadway, New York, NY 10018
6. Norme ANSI Z49.2, PRÉVENTION DES INCENDIES LORS DE L'EMPLOI DE PROCÉDÉS DE COUPE ET DE SOUDAGE, disponible auprès de l'American National Standards Institute, 1430 Broadway, New York, NY 10018
7. Norme A6.0 de l'Association Américaine du Soudage (AWS), LE SOUDAGE ET LA COUPE DE CONTENEURS AYANT RENFERMÉ DES PRODUITS COMBUSTIBLES, disponible auprès de la American Welding Society, 550 N.W. LeJeune Rd., Miami, FL 33126
8. Norme 51 de l'Association Américaine pour la Protection contre les Incendies (NFPA), LES SYSTEMES À GAZ AVEC ALIMENTATION EN OXYGENE POUR LE SOUDAGE, LA COUPE ET LES PROCÉDÉS ASSOCIÉS, disponible auprès de la National Fire Protection Association, Batterymarch Park, Quincy, MA 02269
9. Norme 70 de la NFPA, CODE ELECTRIQUE NATIONAL, disponible auprès de la National Fire Protection Association, Batterymarch Park, Quincy, MA 02269
10. Norme 51B de la NFPA, LES PROCÉDÉS DE COUPE ET DE SOUDAGE, disponible auprès de la National Fire Protection Association, Batterymarch Park, Quincy, MA 02269
11. Brochure GCA P-1, LA MANIPULATION SANS RISQUE DES GAZ COMPRIMÉS EN CYLINDRES, disponible auprès de l'Association des Gaz Comprimés (Compressed Gas Association), 1235 Jefferson Davis Highway, Suite 501, Arlington, VA 22202
12. Norme CSA W117.2, CODE DE SÉCURITÉ POUR LE SOUDAGE ET LA COUPE, disponible auprès de l'Association des Normes Canadiennes, Standards Sales, 178 Rexdale Boulevard, Rexdale, Ontario, Canada, M9W 1R3
13. ivret NWSA, BIBLIOGRAPHIE SUR LA SÉCURITÉ DU SOUDAGE, disponible auprès de l'Association Nationale de Fournitures de Soudage (National Welding Supply Association), 1900 Arch Street, Philadelphia, PA 19103
14. Norme AWSF4.1 de l'Association Américaine de Soudage, RECOMMANDATIONS DE PRATIQUES SURES POUR LA PRÉPARATION À LA COUPE ET AU SOUDAGE DE CONTENEURS ET TUYAUX AYANT RENFERMÉ DES PRODUITS DANGEREUX , disponible auprès de la American Welding Society, 550 N.W. LeJeune Rd., Miami, FL 33126
15. Norme ANSI Z88.2, PRATIQUES DE PROTECTION RESPIRATOIRE, disponible auprès de l'American National Standards Institute, 1430 Broadway, New York, NY 10018

1.07 Declaration of Conformity

Manufacturer: Thermal Dynamics Corporation
Address: Industrial Park #2
West Lebanon, New Hampshire 03784
USA

The equipment described in this manual conforms to all applicable aspects and regulations of the 'Low Voltage Directive' (European Council Directive 73/23/EEC as amended by Council Directive 93/68/EEC) and to the National legislation for the enforcement of this Directive.

Serial numbers are unique with each individual piece of equipment and details description, parts used to manufacture a unit and date of manufacture.

National Standard and Technical Specifications

The product is designed and manufactured to a number of standards and technical requirements among them are:

- * CSA (Canadian Standards Association) standard C22.2 number 60 for Arc welding equipment.
- * UL (Underwriters Laboratory) rating 94VO flammability testing for all printed-circuit boards used.
- * ISO/IEC 60974-1 (BS 638-PT10) (EN 60 974-1) applicable to welding equipment and associated accessories.
- * Extensive product design verification is conducted at the manufacturing facility as part of the routine design and manufacturing process. This is to ensure the product is safe, when used according to instructions in this manual and related industry standards, and performs as specified. Rigorous testing is incorporated into the manufacturing process to ensure the manufactured product meets or exceeds all design specifications.

Thermal Dynamics has been manufacturing products for more than 30 years, and will continue to achieve excellence in our area of manufacture.

Manufacturers responsible representative: David Ashworth
Vice President & Managing Director
Thermadyne Europe
Chorley England.

1.08 Statement of Warranty

LIMITED WARRANTY: Thermal Dynamics® Corporation (hereinafter “Thermal”) warrants that its products will be free of defects in workmanship or material. Should any failure to conform to this warranty appear within the time period applicable to the Thermal products as stated below, Thermal shall, upon notification thereof and substantiation that the product has been stored, installed, operated, and maintained in accordance with Thermal’s specifications, instructions, recommendations and recognized standard industry practice, and not subject to misuse, repair, neglect, alteration, or accident, correct such defects by suitable repair or replacement, at Thermal’s sole option, of any components or parts of the product determined by Thermal to be defective.

THIS WARRANTY IS EXCLUSIVE AND IS IN LIEU OF ANY WARRANTY OF MERCHANTABILITY OR FITNESS FOR A PARTICULAR PURPOSE.

LIMITATION OF LIABILITY: Thermal shall not under any circumstances be liable for special or consequential damages, such as, but not limited to, damage or loss of purchased or replacement goods, or claims of customers of distributor (hereinafter “Purchaser”) for service interruption. The remedies of the Purchaser set forth herein are exclusive and the liability of Thermal with respect to any contract, or anything done in connection therewith such as the performance or breach thereof, or from the manufacture, sale, delivery, resale, or use of any goods covered by or furnished by Thermal whether arising out of contract, negligence, strict tort, or under any warranty, or otherwise, shall not, except as expressly provided herein, exceed the price of the goods upon which such liability is based.

THIS WARRANTY BECOMES INVALID IF REPLACEMENT PARTS OR ACCESSORIES ARE USED WHICH MAY IMPAIR THE SAFETY OR PERFORMANCE OF ANY THERMAL PRODUCT.

THIS WARRANTY IS INVALID IF THE PRODUCT IS SOLD BY NON-AUTHORIZED PERSONS.

The limited warranty periods for Thermal products shall be as follows (with the exception of STAK PAK II and DRAG-GUN): A maximum of three (3) years from date of sale to an authorized distributor and a maximum of two (2) years from date of sale by such distributor to the Purchaser, and with the further limitations on such two (2) year period (see chart below).

The limited warranty period for STAK PAK II shall be as follows: A maximum of four (4) years from date of sale to an authorized distributor and a maximum of three (3) years from date of sale by such distributor to the Purchaser, and with the further limitations on such three (3) year period (see chart below).

The limited warranty period for DRAG-GUN shall be as follows: A maximum of two (2) years from date of sale to an authorized distributor and a maximum of one (1) year from date of sale by such distributor to the Purchaser, and with the further limitations on such two (2) year period (see chart below).

<u>PAK UNITS, POWER SUPPLIES</u>	<u>PARTS STAK PAK II</u>	<u>PARTS DRAG-GUN</u>	<u>PARTS ALL OTHERS</u>	<u>LABOR</u>
Main Power Magnetics	3 Years	1 Year	2 Years	1 Year
Original Main Power Rectifier	3 Years	1 Year	2 Years	1 Year
Control PC Board	3 Years	1 Year	2 Years	1 Year
All Other Circuits And Components Including, But Not Limited To, Starting Circuit, Contactors, Relays, Solenoids, Pumps, Power Switching Semi-Conductors	1 Year	1 Year	1 Year	1 Year
<u>CONSOLES, CONTROL EQUIPMENT, HEAT EXCHANGES, AND ACCESSORY EQUIPMENT</u>	1 Year		1 Year	1 Year
<u>TORCH AND LEADS</u>				
Maximizer 300 Torch	N/A		1 Year	1 Year
All Other Torches	180 Days	180 Days	180 Days	180 Days
<u>REPAIR/REPLACEMENT PARTS</u>	90 Days	90 Days	90 Days	None

Warranty repairs or replacement claims under this limited warranty must be submitted by an authorized Thermal Dynamics® repair facility within thirty (30) days of the repair. No transportation costs of any kind will be paid under this warranty. Transportation charges to send products to an authorized warranty repair facility shall be the responsibility of the customer. All returned goods shall be at the customer’s risk and expense. This warranty supersedes all previous Thermal warranties.

Effective May 19, 1998

SECTION 2: INTRODUCTION & DESCRIPTION

2.01 SYSTEM SPECIFICATIONS

***Econo-pak 50
Air Plasma Cutting
System Includes:***

- Econo-pak 50 - The power supply provides 35 amps maximum output cutting current from a standard 208-230 volt, 60Hz AC input service. All electrical, pilot, and gas control circuitry is included.
- Hand Torch with Leads. Cut capacity is 1/2 inch (12.8 mm) steel. Parts-In-Place (PIP) is an integral safety feature of this torch to reduce the risk of electric shock.
- Spare Parts Kit.





SPECIFICATIONS	
<i>Controls</i>	<ul style="list-style-type: none"> • ON/OFF Switch • RUN/SET Switch • Output Current Control • Pressure Regulator Control
<i>Panel Indicators</i>	LED Indicators: AC Power, READY Pressure Gauge
<i>Input Power</i>	208-230 VAC, 60 Hz, 25/30 Amp Single Phase
<i>Output Power</i>	Continuously variable from 15 to 35 Amps maximum
<i>OCV</i>	330 VDC
<i>Duty Cycle</i>	40%
<i>Work Lead</i>	10 ft (3 m) with clamp
<i>Cut Capacity</i>	1/2 in (12.8 mm) Steel
<i>Pilot Circuitry</i>	Capacitor Discharge (CD), Pulsed DC
<i>Gas Connection</i>	Rear panel entry 1/4 NPT
<i>Gases</i>	Compressed Air or Nitrogen (N ₂) Only
<i>Pressure</i>	60 psi (4.2 BAR)
<i>Flow</i>	135 scfh (64 lpm)
<i>Weight</i>	70 lbs (32 kg) with 12.5' Torch Leads
<i>Dimensions</i>	20 3/4" (527 mm) High 9 3/4" (248 mm) Wide 25" (635 mm) Deep

2.02 TORCH PARTS

Torch Parts Selection

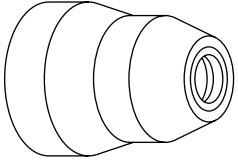
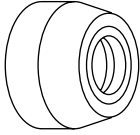
The same torch parts are used for drag cutting and standoff cutting. See Section 5.03, Replacing Consumable Torch Parts.

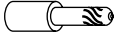
Order replacement parts by catalog number and description.

 <p>Standard Shield Cup Catalog No. 9-6003</p>	 <p>Shield Cup Attachment (Copper) Catalog No. 9-6503</p>
 <p>Drag Cutting Tip (0.031 inch Orifice) Catalog No. 9-6501</p>	
 <p>Electrode Catalog No. 9-6506</p>	 <p>Gas Distributor Catalog No. 9-6507</p>

A-01745

SECTION 3: INSTALLATION

3.01 UNPACKING AND CHOOSING A LOCATION

What's Included with the Power Supply

Included with each system is:

- (1) Work Cable with Clamp (Attached)
- (1) 230V Single-Phase, Three Wire Input Power Cable (Attached)
- (1) Operating Manual
- (1) Spare Parts Kit - Includes:
 - (5) Drag Cutting Tips Part No. 9-6501
 - (3) Electrodes Part No. 9-6506
 - (1) Gas Distributor Part No. 9-6507

Unpacking Procedure

1. Unpack each item and remove all packing material.
2. Inspect each item for possible shipping damage. If damage is evident, contact your distributor and/or shipping company before proceeding with system installation.

Choosing a Location

Select a clean, dry location with good ventilation and adequate working space around all components.

The power supply is cooled by air flow through the front and rear panels. Air flow must not be obstructed. Provide at least 12 inches (300 mm) clearance for both front and rear of system.

CAUTION

Operation without proper air flow will inhibit proper cooling and reduce duty cycle.

NOTE

Review Important Safety Precautions (page *iii*) to be sure that the selected location meets all safety requirements.

3.02 ELECTRICAL CONNECTIONS

Power Requirements

The unit will operate on single phase 208-230 VAC, 60 Hz. The service should be fused for 30 amps.

CAUTION

The primary power source, power cable, and plug must conform to local electric code and recommended circuit protection and wiring requirements.

3.03 GAS CONNECTIONS

Gases	Compressed Air or Nitrogen (N ₂), Only
Pressure	60 psi (4.2 BAR)
Flow	135 scfh (64 lpm)

CAUTION Maximum input gas pressure must not exceed 125 psi (8.6 BAR).



WARNING This cutting system must not be used with Oxygen (O₂).

CAUTION Air supply must be free of oil, moisture, and other contaminants. Excessive oil and moisture may cause double-arcing, rapid tip wear, or even complete torch failure. Contaminants may cause poor cutting performance and rapid electrode wear.

Checking Air Quality To test the quality of air, place a welding filter lens in front of the torch and turn on the gas. Any oil or moisture in the air will be visible on the lens. Do not initiate an arc!

Filtering An air line filter, capable of filtering to at least 5 microns, is required when using air from a compressor to insure that moisture and debris from the supply hose does not enter the torch.

Gas Connections The rear panel of the power supply is equipped with a female 1/4 NPT gas input fitting.

Using High Pressure Gas Cylinders To use air or nitrogen from a high pressure gas cylinder:

1. Examine the cylinder valves to be sure they are clean and free of oil, grease or any foreign material. Momentarily open each cylinder valve to blow out any dust which may be present.
2. Each cylinder must be equipped with an adjustable high-pressure regulator capable of pressures up to 75 psi (5.3 BAR) minimum and flows of up to 200 scfh (94 lpm).
3. Set the tank regulator to 75 psi (5.3 BAR). Use the regulator on the front of the power supply to adjust the gas pressure to the unit.

NOTE Refer to the manufacturer's specifications for installation and maintenance procedures for high pressure gas regulators.

CAUTION Do not use an air line filter with high pressure gas cylinders.

3.03 GAS CONNECTIONS (Continued)

CAUTION

To use shop air from a compressor, refer to Figure 3-A and:

Air supply must be free of oil, moisture, and other contaminants. Excessive oil and moisture may cause double-arcing, rapid tip wear, or even complete torch failure. Contaminants may cause poor cutting performance and rapid electrode wear.

Replacing Filter Cartridge

1. Install an air filter assembly to the gas input fitting on the front panel of the power supply. The air filter is supplied with 1/4 NPT gas couplings. A quick disconnect fitting is recommended on the filter body cap to allow easy connection to the compressed air source.
2. Connect the air supply hose to the inlet fitting on the air filter body cap.

NOTE

When connecting a gas fitting to the filter cap, hold the cap flats with a wrench. Over tightening the cap on the filter body can damage the filter cartridge or cap gasket.

Air filter cartridge (Part No. 7-0252) should be replaced every 30 days, depending on the condition of the compressed air. If a noticeable drop in air pressure occurs, the filter has become filled with contaminants and must be replaced.

To replace cartridge, unscrew filter cap from body, slide out old cartridge and insert new filter element. The filter cartridge fits only one way. **Filter cap must be hand tight only.**

Supply hoses must be at least #4 hose (1/4 in or 6.4 mm minimum inside diameter).

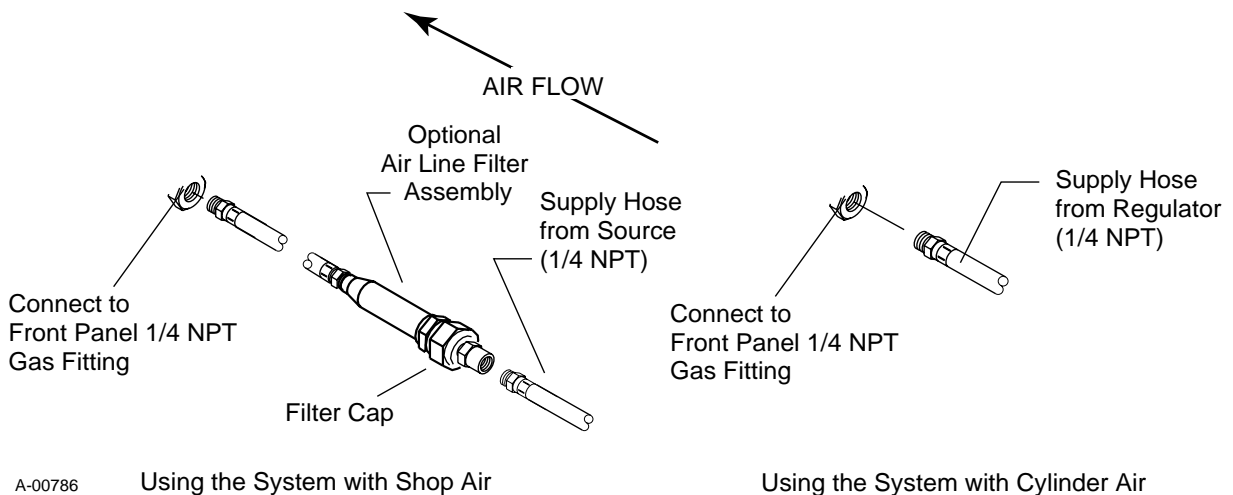

Figure 3-A Air Line Filter Gas Connections

SECTION 4: OPERATION

4.01 OPERATING CONTROLS



A-01746

<i>RUN/SET Switch</i>	RUN position is used for torch operation. SET position is used for setting gas pressure and purging lines.
<i>AC Indicator</i>	Green light indicates AC input power is present in the system when the ON/OFF switch is in ON position. Indicator will flash for a few seconds when first turned on until the power circuits are ready.
<i>READY Indicator</i>	Green light indicates system ready for operation. Light will be off if the system is overheated or the AC line input voltage is too high. The indicator will also flash for a moment if the torch is shorted.
<i>Current Control</i>	Adjusts output current from 15 to 35 amps.
<i>ON/OFF Switch</i>	ON position supplies AC power to activate all system control circuits. OFF position deactivates control circuits.
<i>Pressure Gauge</i>	Displays input pressure to the torch.
<i>Pressure Control</i>	Adjusts pressure from the regulator. Pull knob out and turn clockwise to increase pressure to desired level. Push Knob in to lock setting.

4.02 GETTING STARTED



WARNING

Disconnect primary power at the source before disassembling the power supply, torch, or torch leads.

Check Torch Parts

Follow this set-up procedure each time the system is operated:

1. Check the torch for proper assembly and appropriate front end torch parts (see Section 5.03, Replacing Consumable Torch Parts).

NOTE

The power supply will not operate unless the torch shield cup is fully seated against the PIP (Parts in Place) pins in the torch head.

Check Input Power

2. Check the power source for proper input voltage. Make sure the power source meets circuit protection and wiring requirements.

Connect Work Cable

3. Check for a solid work cable connection to the workpiece.

Check Gas Supply

4. Select desired gas (air or nitrogen). Make sure gas sources meet pressure and flow requirements (see Section 3.03, Gas Connections). Check connections and turn gas supply on.

Select Output Current

5. Select the desired current output level (15 to 35 amps).

Set Operating Pressure

7. Move the RUN/SET switch to SET position. Adjust the gas pressure to 60 psi (4.2 BAR).

8. Set the RUN/SET switch to RUN position.

The system is now ready for operation.

4.03 OPERATING THE SYSTEM

	WARNING	Disconnect primary power at the source before disassembling the power supply, torch, or torch leads.
---	----------------	--

	WARNING	Frequently review the Important Safety Precautions at the front of this Manual. Be sure the operator is equipped with proper gloves, clothing, eye and ear protection. Make sure no part of the operator's body comes into contact with the workpiece while the torch is activated.
---	----------------	---

	CAUTION	Sparks from the cutting process can cause damage to coated, painted, and other surfaces such as glass, plastic and metal.
	NOTE	Handle torch leads with care and protect them from damage.
	<i>Piloting</i>	Piloting is harder on parts life than actual cutting because the pilot arc is directed from the electrode to the tip rather than to a workpiece. Whenever possible, avoid excessive pilot arc time to improve parts life.
	<i>Torch Standoff</i>	Improper standoff (the distance between the torch tip and workpiece) can adversely affect tip life as well as shield cup life. Standoff may also significantly affect the bevel angle. Reducing standoff will generally result in a more square cut.
	<i>Edge Starting</i>	For edge starts, hold the torch perpendicular to the workpiece with the front of the tip on the edge of the workpiece at the point where the cut is to start. When starting at the edge of the plate, do not pause at the edge and force the arc to "reach" for the edge of the metal. Establish the cutting arc as quickly as possible.
	<i>Direction of Cut</i>	In the torch, the plasma gas stream swirls as it leaves the torch to maintain a smooth column of gas. This swirl effect results in one side of a cut being more square than the other. Viewed along the direction of travel, the right side of the cut is more square than the left. To make a square-edged cut along an inside diameter of a circle, the torch should move counter clockwise around the circle. To keep the square edge along an outside diameter cut, the torch should travel in a clockwise direction.
	<i>Dross</i>	On carbon steel, dross on top of the plate is normally caused by a fast torch travel speed or a high torch standoff. This dross is usually hard to remove. Dross along the cut line on the bottom of the plate is more easily removed and is often caused by torch travel speeds that are too slow.

4.03 OPERATING THE SYSTEM (continued)

Common Cutting Problems	
Problem	Possible Cause
Insufficient Penetration	<ol style="list-style-type: none"> 1. Cutting speed too fast 2. Torch tilted too much 3. Metal too thick 4. Worn torch parts 5. Cutting current too low
Main Arc Extinguishes	<ol style="list-style-type: none"> 1. Cutting speed too slow 2. Torch standoff too high from workpiece 3. AC line too low - reduce output current 4. Work cable disconnected 5. Worn torch parts
Excessive Dross Formation	<ol style="list-style-type: none"> 1. Cutting speed too slow (bottom dross) 2. Cutting speed too fast (top dross) 3. Torch standoff too high from workpiece 4. Improper cutting current 5. Worn torch parts
Short Torch Parts Life	<ol style="list-style-type: none"> 1. Oil or moisture in air source 2. Exceeding system capability (material too thick) 3. Excessive pilot arc time 4. Air flow too low (incorrect pressure) 5. Improperly assembled torch

Table 4-B Common Causes of Operating Problems

4.04 OPERATING WITH A HAND TORCH

Cutting with a Hand Torch

1. The torch can be comfortably held in one hand or steadied with two hands. Choose the technique that feels most comfortable and allows good control and movement. Position the index finger or thumb to press the control switch on the torch handle.
2. For edge starts, hold the torch perpendicular to the workpiece with the front of the tip on the edge of the workpiece at the point where the cut is to start. For piercing, angle the torch slightly to direct sparks away from the torch until the pierce is complete.
3. For drag cuts keep the torch in contact with the workpiece. For standoff cutting, hold the torch 1/16 -1/8 in (2-3 mm) from the work.
4. With the torch in starting position, press and hold the control switch. After an initial gas purge, the pilot arc will come on and remain on until the cutting arc starts.
5. Once on, the main arc remains on as long as the control switch is held down, unless the torch is withdrawn from the work or torch motion is too slow. If the cutting arc is interrupted, the pilot arc comes back on automatically.
6. To shut off the torch simply release the control switch. When the switch is released a ten second post-flow will occur. If the torch switch is closed during the post-flow, the cutting arc will restart immediately when the torch is brought within range of the workpiece.

Piercing with a Hand Torch

1. When piercing with a hand torch, tip the torch slightly so that blowback particles blow away from the torch tip (and operator) rather than directly back into it.
2. Complete the pierce off the cutting line and then continue the cut onto the line. Hold the torch perpendicular to the workpiece after the pierce is complete.
3. Clean spatter and scale from the shield cup and the tip as soon as possible. Spraying or dipping the shield cup in anti-spatter compound will minimize the amount of scale which adheres to it.

4.05 RECOMMENDED CUTTING SPEEDS

Recommended Cutting Speeds

Cutting speed depends on material, thickness, and the operator's ability to accurately follow the desired cut line. The following factors may have an impact on system performance:

- Torch parts wear
- Air quality
- Line voltage fluctuations
- Torch standoff height
- Proper work cable connection

NOTE

This information represents realistic expectations using recommended practices and well-maintained systems. Actual speeds may vary up to 50% from those shown.

Material	Thickness	Cut Speed (IPM)	Amps	Gas / Pressure	Stand Off
Mild Steel	1/16" (1.6 mm)	200	35	Air / 60 psi	Drag - 1/8"
	1/8" (3.2 mm)	100	35	Air / 60 psi	Drag - 1/8"
	1/4" (6.4 mm)	35	35	Air / 60 psi	Drag - 1/8"
	3/8" (9.6 mm)	15	35	Air / 60 psi	Drag - 1/8"
	1/2" (12.8 mm)	10	35	Air / 60 psi	Drag - 1/16"

Tables 4-C Recommended Cutting Speeds

SECTION 5: CUSTOMER/OPERATOR SERVICE

5.01 TROUBLESHOOTING AND MAINTENANCE

General | Basic troubleshooting of the Econo-pak 50 plasma cutting system can be performed without special equipment or knowledge, and without opening the enclosure.

This basic troubleshooting guide covers input power, gas supply, and torch problems.

NOTE | For problems not covered in this Section, contact your authorized distributor.

Routine Maintenance | The only routine maintenance required for the power supply is a thorough cleaning and inspection, with the frequency depending on the usage and the operating environment.



WARNING

Disconnect primary power to the system before disassembling the torch, leads, or power supply.

CAUTION

Do not blow air into the power supply during cleaning. Blowing air into the unit can cause metal particles to interfere with sensitive electrical components and cause damage to the unit.

To clean the unit, open the enclosure and use a vacuum cleaner to remove any accumulated dirt and dust. The unit should also be wiped clean. If necessary, solvents that are recommended for cleaning electrical apparatus may be used.

CAUTION

When cleaning care must be taken not to move or damage the electronic components.

5.02 BASIC TROUBLESHOOTING GUIDE

SYMPTOM	POSSIBLE CAUSE	REMEDY
A. AC indicator not lit. Fan does not turn.	1. Circuit Breaker open.	1. Reset Breaker. Use 30 amp service.
B. AC indicator lit. READY indicator dark.	1. Unit is overheated. 2. Airflow obstructed. 3. Pilot circuit overheated. Indicator lits momentarily and unit shuts down.	1. Make sure the unit has not been operated beyond 40% duty cycle limit. 2. Provide at least 12 inch clearance front and rear 3. Check for proper torch parts assembly, or for shorted torch head.
C. AC indicator lit, READY indicator lit, no gas flow in SET.	1. Gas not connected or pressure too low. 2. Air filter or air line blocked or Torch leads blocked	1. Check source for at least 60 psi (4.2 BAR). In SET position, adjust gas pressure to 60 psi. 2. Replace filter cartridge. Check that air lines and torch leads are free of twists and kinks.
D. AC indicator lit, READY indicator lit, no gas flow in RUN when torch swirch pressed.	1. Shield cup not properly installed on torch. 2. Faulty PIP assembly in torch holder.	1. Check that shield cup is fully seated against torch head. 2. Replace Torch Head Assembly.
E. AC indicator lit, READY indicator lit, Torch does not pilot.	1. Faulty torch parts 2. Gas pressure too high.	1. Inspect torch parts and replace if necessary. 2. Set pressure to 60 psi (4.2 BAR).
F. Torch pilots but does not cut.	1. Work lead not connected. 2. AC input too low.	1. Make sure work lead is connected securely to bare metal. 2. Use shortest service to breaker panel possible.

5.03 REPLACING CONSUMABLE TORCH PARTS

	WARNING	Disconnect primary power to the system before disassembling the torch, leads, or power supply.
---	----------------	--

	WARNING	DO NOT TOUCH internal torch parts while the AC indicator on the front panel of the power supply is lit.
---	----------------	---

NOTE

The tip, gas distributor, and electrode are held in place by the shield cup. Position the torch with the shield cup facing upward to prevent these parts from falling out when the cup is removed.

Refer to Figure 5-A and:

1. Unscrew and remove the shield cup from the torch. Inspect the cup for damage. Wipe it clean or replace if damaged.
2. Remove the tip. Check for excessive wear (indicated by an elongated or oversized orifice). Clean and replace the tip if necessary.
3. Remove the gas distributor and check for excessive wear, plugged gas holes, or discoloration. Replace if necessary.
4. Remove the electrode. The face of the electrode should not be recessed more than 0.10 inch (2.5 mm). If it is worn beyond this point it must be replaced.
5. Reinstall the parts and shield cup on the torch as shown. Hand tighten the shield cup until it is seated on the torch head. If resistance is felt when installing the cup, check the threads before proceeding with installation.



CAUTION

Improper assembly or use of non standard torch parts can cause the torch head to short and may overheat or damage the torch.

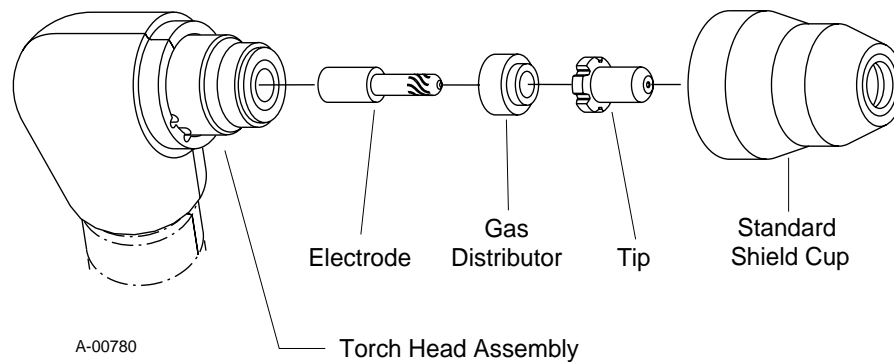

Figure 5-A Torch Consumable Parts

SECTION 6: PARTS LISTS

6.01 INTRODUCTION

About the Parts List	This Section contains the Parts Lists and Replacement Parts. Parts listed without item numbers are not shown, but may be ordered by the catalog number shown.
Ordering Information	Order replacement parts by catalog number and complete description of the part or assembly, as listed in the description column of the Parts List. Also include the model and serial number of the torch. Address all inquiries to your authorized Thermal Dynamics distributor.
Returns	If a Thermal Dynamics product must be returned for service, contact your Thermal Dynamics distributor. Materials returned to Thermal Dynamics without proper authorization will not be accepted.

6.02 REPLACEMENT - COMPLETE SYSTEMS

Complete systems include: Power Supply with primary power cable, Work Cable, PCH-26 Torch with Leads, Torch Spare Parts Kit, and Operating Manual.

Description	Qty	Catalog #
Econo-Pak 50 with PCH-26 70° Torch		
208/230 Volt Single Phase with 12.5 ft (3.8 m) Leads	1	1-3500-2
208/230 Volt Single Phase with 25 ft (7.6 m) Leads	1	1-3501-2
Econo-Pak 50 with PCH-26 90° Torch		
208/230 Volt Single Phase with 12.5 ft (3.8 m) Leads	1	1-3500-1
208/230 Volt Single Phase with 25 ft (7.6 m) Leads	1	1-3501-1

6.03 REPLACEMENT TORCH AND LEAD ASSEMBLIES

Description	Qty	Catalog #
Replacement Torch With Leads Only:		
PCH-26 70° Hand Torch with 12.5 ft (3.8 m) Leads	1	2-3501
PCH-26 70° Hand Torch with 25 ft (7.6 m) Leads	1	2-3511
PCH-26 90° Hand Torch with 12.5 ft (3.8 m) Leads	1	2-3500
PCH-26 90° Hand Torch with 25 ft (7.6 m) Leads	1	2-3510

6.04 OPTIONS AND ACCESSORIES

Description	Qty	Catalog #
Single Stage Air Filter Kit	1	7-0250
Replacement Air Filter Cartridge	1	7-0252
Dual Stage Air Filter	1	7-3500
First Stage Replacement Cartridge	1	9-1021
Second Stage Replacement Cartridge	1	9-1022
Smart Cart	1	7-7777
Circle Cutting Guide	1	7-3291
Spare Parts Kit	1	5-3500
Tip, Air, 0.031 inch Orifice, Drag Cutting	5	9-6501
Electrode, Air	3	9-6506
Distributor, Gas	1	9-6507
Box, Utility	1	8-3213

6.05 REPLACEMENT HAND TORCH PARTS

<u>Item #</u>	<u>Qty</u>	<u>Description</u>	<u>Catalog #</u>
1	1	Assembly, PIP (Parts-In-Place) Pins and Wire	9-6290
2	2	O-Ring	8-0533
3	1	Holder, Torch, Split, PCH-26 70° Two Parts w/Screws	9-6259
	1	Holder, Torch, Split, PCH-26 90° Two Parts w/Screws	9-6260
4	1	Assembly, Basic Head, PCH-26 70°	9-5807
	1	Assembly, Basic Head, PCH-26 90°	9-5808
5	1	Distributor, Gas	9-6507
6	1	Tip, Air, 0.031 inch Orifice, Drag Cutting	9-6501
7	1	Electrode, Air	9-6506
8	1	Shield Cup, Standard	9-6003
	1	Shield Cup Attachment, MaximumLife (Used with 9-6003)	9-6503
9	1	Handle, Split, PCH-26 Two Parts w/Screws	9-6291
10	1	Lead Assembly, Composite Cable	
		12.5 ft (3.8m) Length	4-6071
		25 ft (7.6m) Length	4-6072
11	1	Assembly, Torch Switch	9-1058
12	1	#6-32 x 3/16 Phillips Pan Head Screw	See Note
13	1	#6 Internal Star Washer	See Note

NOTE: Item can be purchased locally.

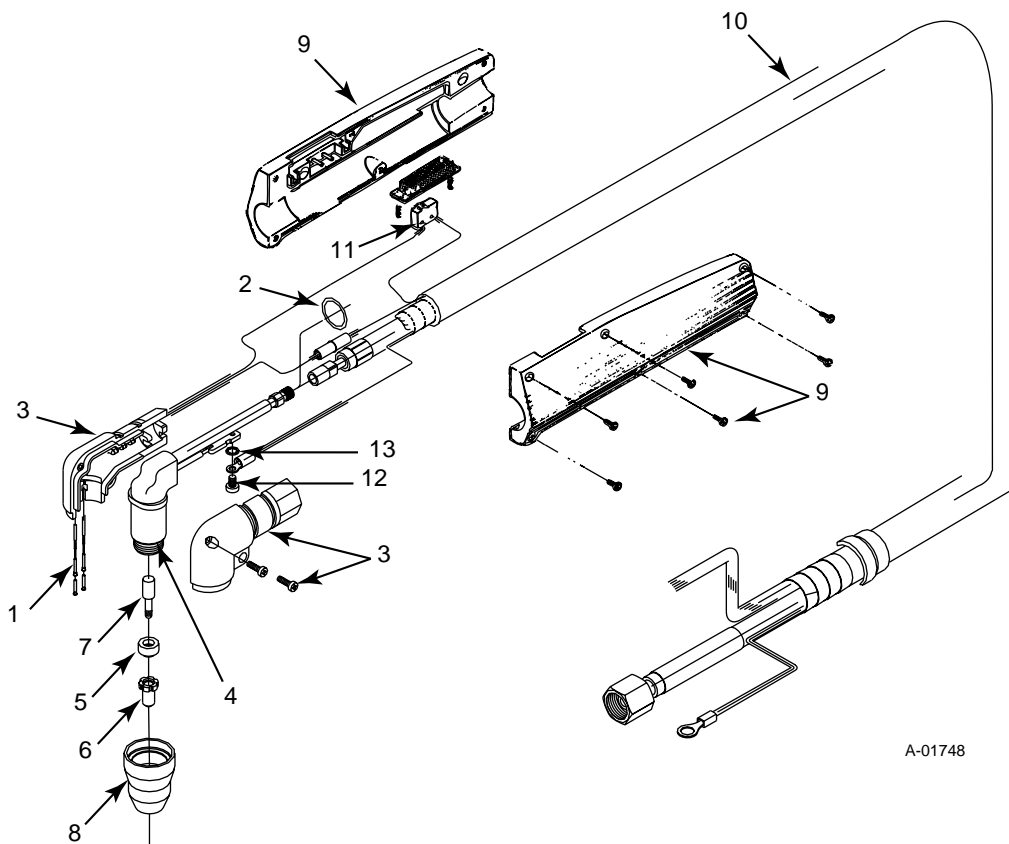

A-01748

This Page Left Blank

